



SIC
SANDWICH ISLANDS COMPOSITES

2019 PRODUCT CATALOG

sicmaui.com [facebook.com/sicmaui](https://www.facebook.com/sicmaui) [instagram.com/sicmaui](https://www.instagram.com/sicmaui)

CONTENTS

SHAPERS NOTES PG 3

F.A.S.T PG 6

RS SERIES PG 8

OKEANOS SERIES PG 10

SONIC SERIES PG 12

BAYONET SERIES PG 14

BULLET SERIES PG 16

F SERIES PG 18

SLICE PRO SERIES PG 20

SLICE SERIES PG 22

SABER SERIES PG 24

TAO SURF SERIES PG 26

SAGE SERIES PG 28

TAO FIT SERIES PG 30

AIR-GLIDE SERIES PG 32

SURFBOARDS PG 34-37

PADDLES PG 38

BAGS PG 40

APPAREL PG 42

ACCESSORIES PG 44

BOARD OVERVIEW PG 46

SHAPERS NOTES:

My inspirational quote for 2018 and what drove my work on the new 2019 shapes is: "Be the work of art in your backyard". This slogan helped me go beyond my normal "make it fast and make it sexy", and allowed me to conceive of slightly humbler designs focused on inspiring and giving confidence to paddlers looking to explore new places or go beyond geographic, emotional and physical boundaries. These new designs reach back to voyager roots as opposed to the traditionally competitive pedigree that SIC has become known for. This year, I wanted to fuse performance with the culture and art I see in my backyard every day, from the Pacific Ocean to the lush forests of Maui.

In the Okeanos this inspiration is manifested in a more traditional look using natural wood and ocean-inspired line-art to symbolize voyaging and the waterman lifestyle. Aesthetically, the artwork spilled over into SIC's new cruising (Saber and Sage) and surf shapes (Slice) which offer a balance of progressive shapes combined with a natural and organic appearance. Don't get me wrong, I'm known as a guy who loves to make the fastest boards on the water, but I also love cruising and surfing with my friends and most of all my wife, Donna. Getting back to the roots of paddling for pleasure helps me remember what compelled me to leave the Netherlands when I was 16, to chase my dreams of becoming a waterman and master the craft of shaping.

Thank you for supporting SIC and for all you do to inspire me. While it may seem like I am a one-man-show, please know that there is whole team of passionate people and paddlers contributing to the creation of SIC's great products. From our team of athletes to the folks in sales, marketing, customer service, shipping, finance, logistics, R&D, QC... There are many people working hard to ensure SIC's aspirations are achieved and that you get the best products possible. SIC has a very special ohana and we hope that you feel this care and the aloha in every SIC product.

I look forward to seeing you on the water

Mahalo nui loa to all.

MR *Mark Raaphorst*



#BOUNDBYWATER

SIC TEAM...FAMILY...HUI...

The SIC team continues to perform at a world class level and highlight that the SIC race boards are some of the fastest in the world. From our Global Elite team to the young guns on the SIC youth development team and our Ambassadors around the world; we are very proud of our teams accomplishments and grateful for their hard work whether they are competing, testing or simply spreading the SIC Aloha around the globe. Every board and product that SIC makes is tested extensively by the team ensuring that by the time you receive yours that it lives up to a world-class performance and best-in-class commitment.

Global Elite Team:

- Kody Kerbox (Hawaii)
- Seychelle (FLA-USA)
- Martin Vitry (France)
- Jade Howson (CA-USA)
- Niuhihi Buillard (Tahiti)
- Caio Vaz (Brazil)

Jr. Development / Regional

- Rai Taguchi (Japan)
- Zeke Rose (CA-USA)
- Keaton Rose (CA-USA)
- Guilherme Cunha (Bazil)
- Riley Jaggi (CA-USA)
- Kaitlin Harvey (CA-USA)
- Bodie Von Allmen (OR-USA)
- Campbell Carter (NC-USA)

National Team

- Mark Raaphorst (Netherlands/Hawaii)
- Tommy Buday (Canada)
- Andrea Moller (Hawaii)
- Livio Menelau (Hawaii)
- Devin Blish (Hawaii)
- Jeremy Riggs (Hawaii)
- Alexis Daniels (France)
- Mariecarmen Rivera (Puerto Rico)
- Greg Closier (France)
- Shou Kikukawa (Japan)
- Miguel Beltran (Puerto Rico)
- Giordano Bruno Capparella (Italy)
- Miguel Martinez (Puerto Rico)
- Scott Trudon (Hawaii)

Regional Ambassadors: Sarah Muir Westbrook, Will Schmidt, Kate Lewis, Teene Froiseth, Justin Schaay, Robert Hess, Hasan Is-mial, Yan Lauletta, Mike Eisert, Ben Gareiss, Joel Yang, Coli Yang, Russel Peart, LouAnne Harris, Jack Martin, Lambert Lo, Joseph Gueguen, Robert Howson, Alex Michaelman, Jose Gonzalles, Matt Hite, Hidehiko Fukushima, Kiyonobu Kanemitus

For more information about the SIC team visit: sicmaui.com/team/

FAST

FOOT ACTUATED STEERING TECHNOLOGY

The mission for the patented F.A.S.T. (Foot Actuated Steering Technology) was to revolutionize the steering that SIC originally created and integrated into stand-up paddle boards. The new F.A.S.T. system performs better than our original system (A.S.S. – Active Steering System) and is far more advanced than any other steering mechanism on the market today.

FAST MODELS:

BAYONET 17.1, BULLET 17.4, BULLET 14.0 V2

1. LOW PROFILE, HIGH QUALITY POLYCARBONATE TILLER ARM WITH EVA FOAM PADDING FOR GRIP AND COMFORT
2. PUSH-ROD CONTROLLED STEERING COMES PRE INSTALLED
3. CANTILEVER C-SPRING CONTROLLED TILLER ARM
4. PUSH-RODS CAN BE HARVESTED AND REPLACED IN THE EVENT OF FAILURE
5. DUMMY TILLER CUP CAN BE SWITCHED WITH ACTIVE TILLER IN MINUTES TO CHANGE FROM REGULAR TO GOOFY FOOTED PADDLERS
6. NEW RUDDER CUP DESIGN INTERNALIZES ALL STEERING MECHANISMS FOR A CLEANER DECK SURFACE AND ASSISTANCE IN ALIGNMENT



7. RUDDER LOCK OFF SWITCH OPTION OR SAFETY FAILOVER

8. DAGGER RUDDER EQUIPPED

9. FINBOX ALSO ALLOWS FOR STANDARD LONGBOARD FIN INSTALLATION

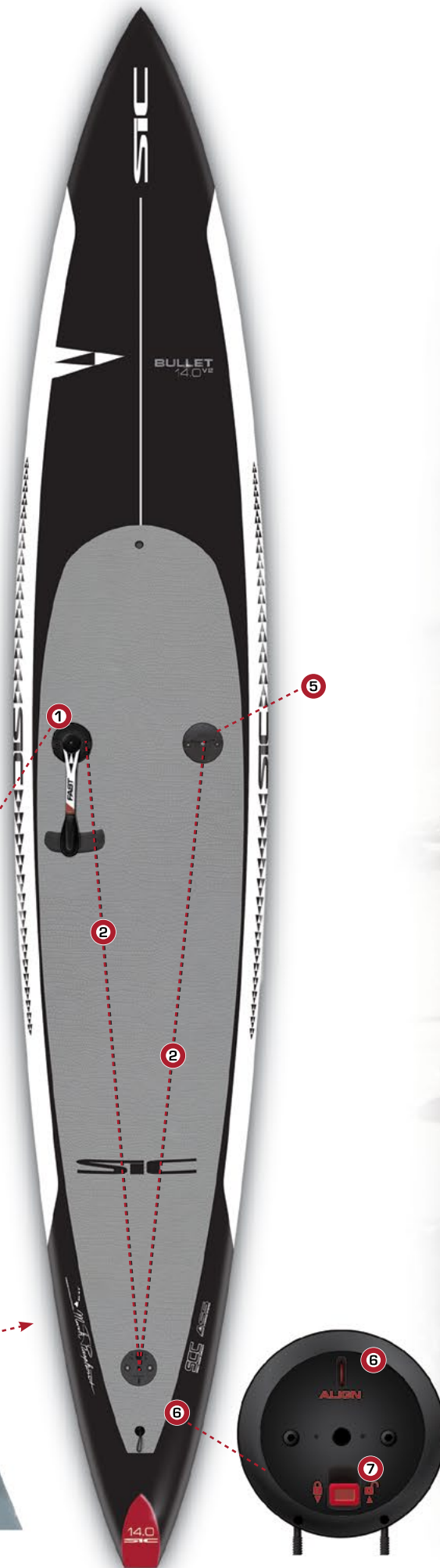
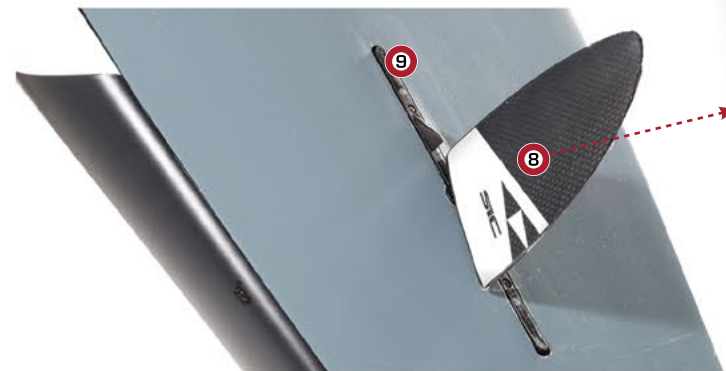

RESPONSIVE PERFORMANCE DURABLE • RELIABILITY AND REDUNDANCY • SERVICEABILITY AND INTERCHANGEABILITY

RACE + TOUR



SUP SURF + EXPLORE



CRUISE + EXPLORE



SURF

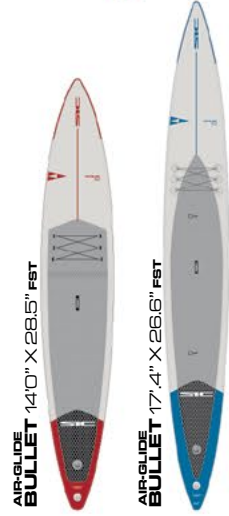

CRUISE + EXPLORE + YOGA



RACE + TOUR

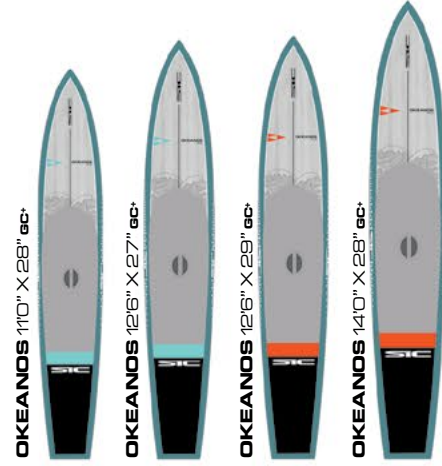

DOWNWIND + TOUR



SUP SURF + EXPLORE

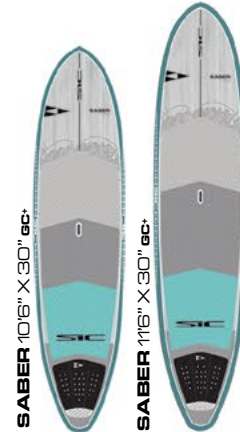

CRUISE + EXPLORE

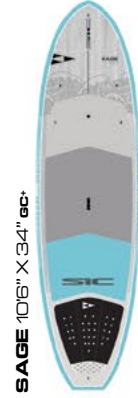

RACE + TOUR



DOWNWIND + TOUR



SURF + EXPLORE

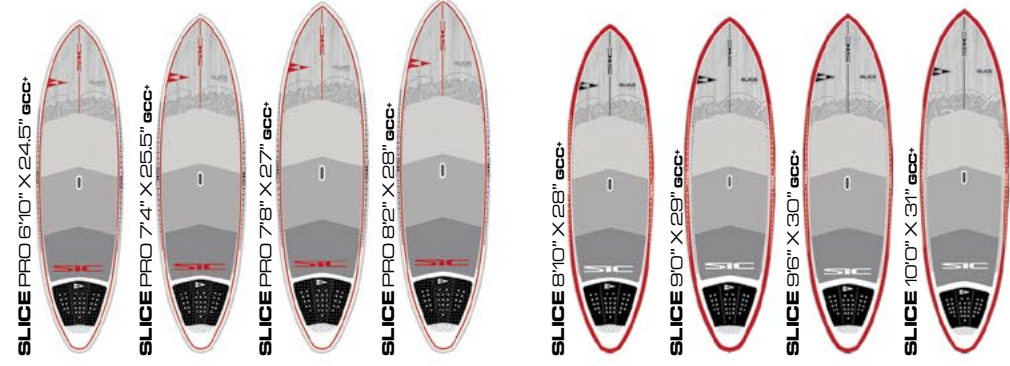

NEW YOUTH SIZES FOR 2019

RS SERIES

ELITE RACE - PERFORMANCE FITNESS / TOURING PADDLING

PERFORMANCE PROFILE YOUTH MODELS:

RS Youth Performance Profile: The RS Youth boards are scaled down versions of the current RS 12.6 x 23.5. and their volumes and widths are right-sized for the smaller / lighter riders who are looking for the fastest designs on the water. The RS Youth features SIC's proprietary Step-Channel™ bottom design which provides unprecedented tracking through the water, allowing you to paddle more on one side before changing over. This helps to maintain a straighter line, higher average speed and greater glide. These boards feature the same SCC+ (SIC Single Carbon Composite Construction + Innegra™) construction as their larger counter parts. These boards have been developed over the past year with an elite squad of young paddlers who train under Coach Mike Eisert at The Paddle Academy. Coach Eisert and his team worked with SIC Founder and Designer Mark Raaphorst to perfect these new production models.

"Getting boards dialed-in with the proper volume and width has always been a challenge and required our athletes to purchase custom boards. Now with this new line of production RS boards, competitive young athletes have the right shapes and volumes to suit their size, weight and power-base." Coach Eisert said, "The new 20" and 22" width RS boards are very light-weight, stable and agile. They accelerate quickly and have a great top-end speed. The RS Youth showed great promise and increased the paddler's performance significantly for the more advanced paddler and had huge impact for our less-experienced athlete."

PERFORMANCE PROFILE:

With a full year of racing and touring under its belt the RS ("Rocket Ship") speeds faster and faster toward its goals as being one of the best all-around race and touring boards in the world. Our athletes have continued to put the RS to the test in technical, long distance, sprint, and downwind races around the world and the RS hits the mark every time with plenty of recent podiums across the globe validating that the RS is truly world-class. Off the racecourse the wider width models have quickly found their fan base and have become a crowd favorite for touring and recreational fitness paddlers alike. With its outstanding stability, acceleration, glide, handling and overall ease of use the RS is elevating the paddling experience. These boards feature SIC Single Carbon Composite Construction + Innegra™ (SCC+) which combines a full wrap biaxial carbon fiber with Innegra™ tip, rail and tail reinforcement, 2-layers of biaxial glass rail reinforcement, 3mm high density PVC deck reinforcement and finish with a crocodile textured EVA deck pad.

KEY FEATURES:

SCC+ (Single Carbon Composite + Innegra™), Step-Channel Bottom, 12K carbon Weedless fin (8.3"), EZ-Grab handle, race handles (2), bungee tie downs, leash plug, Gore-Tex™ breather vent, action camera mount on nose

RS TECHNOLOGY

SINGLE CARBON COMPOSITE + INNEGRA™

1. FULL WRAP BIAXIAL CARBON FIBER
2. INNEGRA™ TIP, RAIL AND TAIL REINFORCEMENT
3. 2-LAYERS BIAXIAL GLASS RAIL REINFORCEMENT
4. 3MM HIGH DENSITY PVC DECK REINFORCEMENT
5. CROCODILE TEXTURED EVA DECK PAD
6. EZ-GRAB CARRYING HANDLE
7. LIGHT WEIGHT CNC/EPS CORE
8. GORE-TEX BREATHER VENT

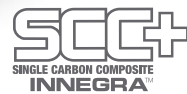
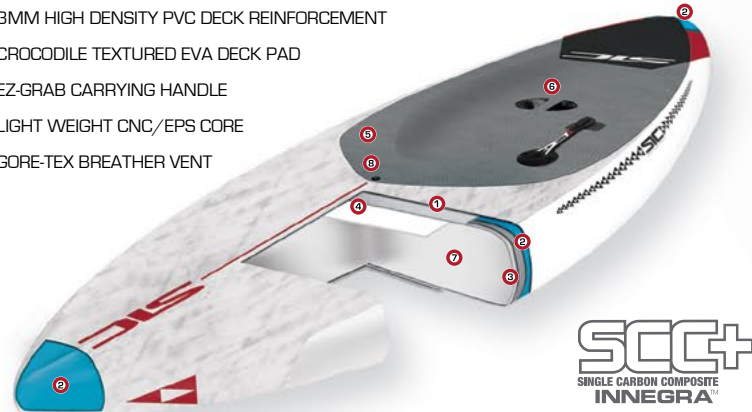

Model	Length	Width	Volume	Weight	Max Rider Weight
NEW YOUTH SIZE SCC+ RS 12.6 LENGTH 12'6" / 381cm WIDTH 20.0" / 50.8cm VOLUME 174L WEIGHT 18.7Lbs / 8.5kgs (+/- 10%) MAX RIDER WEIGHT 120Lbs / 54.4kgs	NEW YOUTH SIZE SCC+ RS 12.6 LENGTH 12'6" / 381cm WIDTH 22.0" / 55.8cm VOLUME 230L WEIGHT 21.6Lbs / 9.8kgs (+/- 10%) MAX RIDER WEIGHT 150Lbs / 68kgs	NEW YOUTH SIZE SCC+ RS 12.6 LENGTH 12'6" / 381cm WIDTH 23.5" / 59.7cm VOLUME 254L WEIGHT 23Lbs / 10.5kgs (+/- 10%) MAX RIDER WEIGHT 150Lbs / 68kgs	NEW YOUTH SIZE SCC+ RS 12.6 LENGTH 12'6" / 381cm WIDTH 25.0" / 63.5cm VOLUME 270L WEIGHT 24.2Lbs / 11.0kgs (+/- 10%) MAX RIDER WEIGHT 150Lbs / 68kgs	NEW YOUTH SIZE SCC+ RS 12.6 LENGTH 12'6" / 381cm WIDTH 26.0" / 66.0cm VOLUME 291L WEIGHT 25.3Lbs / 11.5kgs (+/- 10%) MAX RIDER WEIGHT 150Lbs / 68kgs	
NEW SIZE SCC+ RS 14.0 LENGTH 14'0" / 426.7cm WIDTH 21.5" / 54.6cm VOLUME 253L WEIGHT 23.5Lbs / 10.5kgs (+/- 10%) MAX RIDER WEIGHT 170Lbs / 77.1kgs	NEW SIZE SCC+ RS 14.0 LENGTH 14'0" / 426.7cm WIDTH 23.0" / 58.4cm VOLUME 279L WEIGHT 24.2Lbs / 11kgs (+/- 10%) MAX RIDER WEIGHT 195Lbs / 88.4kgs	NEW SIZE SCC+ RS 14.0 LENGTH 14'0" / 426.7cm WIDTH 24.5" / 62.2cm VOLUME 297L WEIGHT 25.8Lbs / 11.7kgs (+/- 10%) MAX RIDER WEIGHT 220Lbs / 99.8kgs	NEW SIZE SCC+ RS 14.0 LENGTH 14'0" / 426.7cm WIDTH 26.0" / 66.0cm VOLUME 315L WEIGHT 27.3Lbs / 12.4kgs (+/- 10%) MAX RIDER WEIGHT 240Lbs / 108.9kgs	NEW SIZE SCC+ RS 14.0 LENGTH 14'0" / 426.7cm WIDTH 28.0" / 71.1cm VOLUME 340L WEIGHT 28.4Lbs / 12.9kgs (+/- 10%) MAX RIDER WEIGHT 275Lbs / 124.7kgs	

ALL NEW SERIES

OKEANOS SERIES

PERFORMANCE FITNESS / TOURING PADDLING

PERFORMANCE PROFILE:

Okeanos is named after the ancient Greek god of the sea and was further inspired by the NOAA Ship "Okeanos Explorer" located in Pearl Harbor, Hawaii. The purpose of this ship is to systematically explore our largely unknown ocean intent on discovery and the advancement of knowledge. This new series is focused on fitness, touring and voyaging the unknown, so thus the name was chosen. The Okeanos shares similar DNA with the RS series, however, this board is made for recreational paddling and journeying rather than racing. This board paddles with ease and is capable of maintaining a fast pace and efficient glide. The concave in the tail on the bottom helps to maintain a straighter line, higher average speed and greater glide. The nose chine in the bow softens the ride in rough waters and tracks extremely well into the wind and in cross-chop. The generous tail width and full, squared-up rails make this board extremely stable. The wide point in the front section of the board has been shifted forward which also adds to the overall stability. The board has been outfitted with numerous tie-downs and inserts to mount your cargo and accessories. Capable of running either a single fin or two thrusters (sold separately) for paddling in shallow or rocky waters and reducing the draft of the board. This also make beach landings easier and your board will sit stable and secure on the land. The Okeanos is a great fitness board, ready to take on journey and adventure.

KEY FEATURES:

GC+ (Glass Composite + Innegra™) which features a double wrap fiberglass composite layup and oak laminate reinforced top. These boards have been reinforced with Innegra™ in the tip, tail and rails for maximum durability and impact resistance. The board is finished with a comfortable crocodile-textured EVA deck pad, 12K carbon Weedless fin (7.0"/8.3"), FCS2 compatible thruster boxes (thrusters sold separately), EZ-Grab handle, race handles (2), bungee tie, leash plug, Gore-Tex™ breather vent, action camera mount on nose



OKEANOS TECHNOLOGY GLASS COMPOSITE + INNEGRA™

1. DOUBLE WRAP FIBERGLASS COMPOSITE
2. OAK LAMINATE REINFORCED TOP AND BOTTOM
3. LIGHTWEIGHT CNC/EPS CORE
4. INNEGRA™ TIP, RAIL AND TAIL REINFORCEMENT
5. EVA DECKPAD
6. EZ-GRAB HANDLE

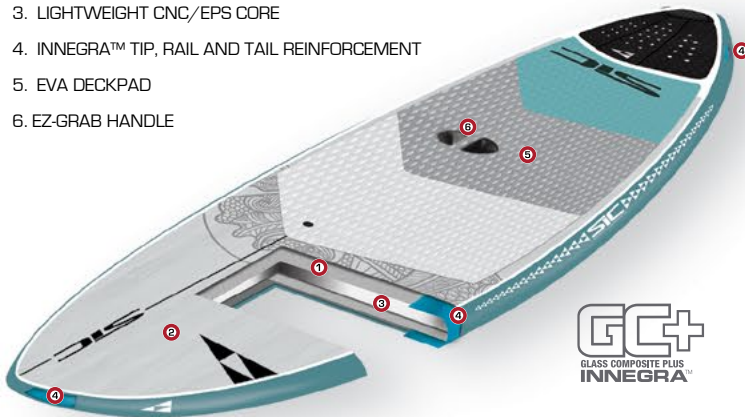

GC+
GLASS COMPOSITE PLUS
INNEGRA™

ALL NEW SERIES

OKEANOS SPECIFICATIONS

Model	GC+ 11.0	GC+ 12.6	GC+ 12.6	GC+ 14.0
FIN SETUP: SINGLE 7.0" WEEDLES + 2 FCS II	FIN SETUP: SINGLE 8.3" WEEDLES + 2 FCS II	FIN SETUP: SINGLE 8.3" WEEDLES + 2 FCS II	FIN SETUP: SINGLE 8.3" WEEDLES + 2 FCS II	FIN SETUP: SINGLE 8.3" WEEDLES + 2 FCS II
LENGTH	11'0"	12'6"	12'6"	14'0"
WIDTH	28.0"	27.0"	29.0"	28.0"
VOLUME	268L	294L	315L	340L
WEIGHT	30LBS	32LBS	33LBS	34LBS
MAX RIDER WEIGHT	250LBS	290LBS	315LBS	350LBS
	13.6KGS (+/- 10%)	14.5KGS (+/- 10%)	14.9KGS (+/- 10%)	15.4KGS (+/- 10%)
	115KGS	130KGS	140KGS	155KGS

RACE + TOUR

ALL NEW SERIES

SONIC SERIES

RECREATIONAL FITNESS / TOUR / RACE

PERFORMANCE PROFILE:

The NEW Sonic 11'0" and 12'6" are the most durable fitness, touring and recreational race boards on the market. Offered at an extremely affordable price point, the Sonic provides a smooth and effortless paddling experience. Whether paddling flatwater, cruising lakes, rivers or the open ocean, touring the Sonic will provide the durable performance you are looking for. It is designed for paddlers looking for a board with excellent glide, stability and versatility. The Sonic is ideal for beginners to intermediate paddlers and has enough flotation to support larger riders or those looking to tandem with a child or pet. The unprecedented durability comes from ST (Space Tec) construction. ST is thermoformed construction technology with tremendous impact and puncture resistance which comes in handy when paddling in rocky areas, storing the board on a boat or sharing with your friends and family. These boards are the perfect boards for resorts, rental and tour operators.

ART SERIES:

The Sonic is part of SIC's "ART Series" boards which utilize a proprietary digital direct printed graphic on the polymer outer skin. They deliver both beauty and durability simultaneously. Each substrate is first printed with a unique design and then thermo-formed over the fiberglass skin. The art is UV stable and scratch resistant. This process allows SIC the flexibility to add durable art that will last for years.

KEY FEATURES:

ST (Space Tec) construction, utilizes a polymer outer skin for impact resistance which is then thermo-formed over fiberglass and a closed cell EPS core for incredible durability, 9.0" FCS Connect Touring fin, smooth textured EVA pad for maximum comfort and non slip grip, Ergo-Undercut handle, bungee tie downs, leash plug

SONIC TECHNOLOGY

SPACE TECH

1. MOLDED, WATERTIGHT EPS FOAM CORE
2. FIBERGLASS WRAP
3. WOVEN FIBERGLASS REINFORCEMENT PATCH
4. WOVEN FIBERGLASS
5. WOVEN FIBERGLASS REINFORCED RAILS
6. THERMOFORMED ASA POLYMER SKIN
7. HONEYCOMB EMBOSSED EVA DECK PAD

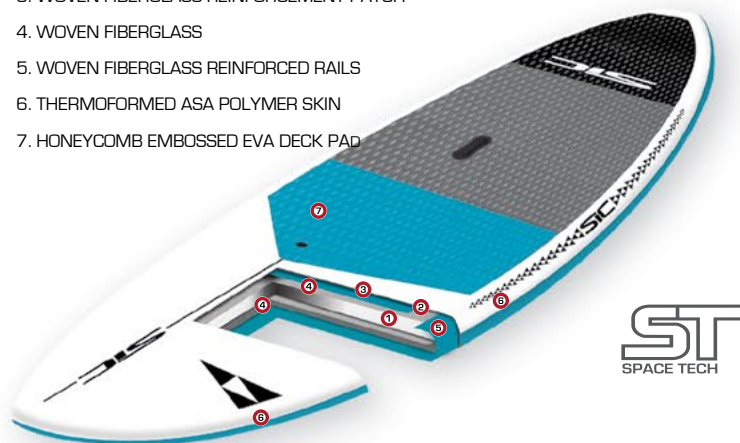

ALL NEW SERIES

SONIC SPECIFICATIONS



FIN SETUP: 9.0" FCS CONNECT TOUR

ST
11.0
 LENGTH
 11'0"
 335cm

WIDTH
 29.0"
 74.0cm

VOLUME
 220L

WEIGHT
 27lbs
 12.5kgs (+/- 10%)

MAX RIDER
 WEIGHT
 170lbs
 75kgs



FIN SETUP: 9.0" FCS CONNECT TOUR

ST
12.6
 LENGTH
 12'6"
 381cm

WIDTH
 30.0"
 76.2cm

VOLUME
 285L

WEIGHT
 34lbs
 15.5kgs (+/- 10%)

MAX RIDER
 WEIGHT
 260lbs
 120kgs

DOWNWIND + TOUR

NEW SIZES FOR 2019

BAYONET SERIES

ELITE DOWN WIND- PERFORMANCE FITNESS / TOURING

12.6 / 14.0 KEY FEATURES: SCC+ (Single Carbon Composite + Innegra™), which combines a full wrap biaxial carbon fiber and Innegra™ reinforcement on the tip, tail and rails as well as an additional biaxial glass rail reinforcement, high density PVC deck reinforcement and finish with a crocodile textured EVA deck pad, 12K carbon Weedless fin 7.0", EZ-Grab handle, bungee tie downs, leash plug, Gore-Tex™ breather vent, action camera mount on nose

17.1 KEY FEATURES:

DCC+ (Double Carbon Composite + Innegra™), which combines two layers of biaxial carbon fiber on both the top and bottom of the board and additional Innegra™ reinforcement on the tip, tail and rails. It is further reinforced with biaxial glass on the rails. This board also comes equipped with F.A.S.T (3k carbon rudder), crocodile-textured EVA deck pad, EZ-Grab carry handle, bungee tie downs, leash plug, Gore-Tex™ breather vent, action camera mount on nose

BAYONET TECHNOLOGY

DOUBLE CARBON COMPOSITE + INNEGRA™

1. FULL WRAP UNI-DIRECTIONAL CARBON FIBER + FULL WRAP BIAXIAL CARBON FIBER
2. INNEGRA™ TIP, RAIL AND TAIL REINFORCEMENT
3. BIAXIAL GLASS RAIL REINFORCEMENT
4. LIGHT WEIGHT CNC/EPS CORE
5. GORE TEX BREATHER VENT
6. PVC DECK REINFORCEMENT
7. CROCODILE TEXTURED EVA DECK PAD
8. EZ-GRAB CARRYING HANDLE



DCC+
DOUBLE CARBON COMPOSITE
INNEGRA™

SINGLE CARBON COMPOSITE + INNEGRA™

1. FULL WRAP BIAXIAL CARBON FIBER
2. INNEGRA™ TIP, RAIL AND TAIL REINFORCEMENT
3. BIAXIAL GLASS RAIL REINFORCEMENT
4. HIGH DENSITY PVC DECK REINFORCEMENT
5. CROCODILE TEXTURED EVA DECK PAD
6. EZ-GRAB CARRYING HANDLE
7. LIGHT WEIGHT CNC/EPS CORE
8. GORE-TEX BREATHER VENT



SCC+
SINGLE CARBON COMPOSITE
INNEGRA™



12.6 / 14.0 PERFORMANCE PROFILE

Performance Profile: The Bayonet Series is not a replacement for the Bullet Series; it is an evolution with a focus on taking all that is good in the Bullet and pushing the limits of what is possible in the Bayonet. With the intended paddler being more accomplished and likely a competitive paddler and/or serious touring and fitness paddler. The Bayonet is the answer to the demands of our elite team and focuses on early planing capability and top-end speed. The Bayonet continues SIC's legacy of having the fastest downwind boards in the world. These boards plane early in sub twenty mph winds, and stay on glide longer, edge well in cross chop and have tremendous rail-to-rail steering when on a bump or wave. They do take a bit more agility with the squarer rail shape which promote stability on the narrow widths. They have a bit less under tuck and therefore are not as forgiving as the Bullets. The lower rocker profile means that the boards are extremely fast at low speed but do require a bit more agility to maneuver back to the tail when on plane and to mitigate nose poke. The Bayonet 14'0" feature Single Carbon Composite Construction + Innegra™ (SCC+)

17.1 PERFORMANCE PROFILE

Victorious in the prestigious M20 (Molokai2Oahu) and M2M Challenge (Maui2Molokai Challenge) and many more, the Bayonet 17'1" continues its open ocean dominance and perpetuates SIC's legacy in downwind and channel crossings. Whether a world-class paddler or advanced recreational paddler, you have never experienced the speed and handling of the Bayonet. The Bayonet was specifically designed to be stable and plane early in lighter winds and smaller swell. Its lower rockered nose and bow design pierce through wind and chop with ease. More volume and deck contour were added to the decking to shed water and return swiftly to the surface when the nose pokes. These features come in handy when paddling on bumps with a closer fetch whether you are paddling on a lake or the Columbia River Gorge where waves are tighter together than on an open ocean swell such as a Maliko run in Maui. The balanced outline provides surprising rail-to rail stability for the boards overall width. The Bayonet 17'1" is constructed in DCC+ construction and comes equipped with SIC's patent FAST (Foot Actuated Steering Technology).

BAYONET SPECIFICATIONS

NEW SIZE	SCC+	SCC+	SCC+	DCC+
12.6	14.0	14.0	14.0	17.1
LENGTH 12'6"	LENGTH 14'0"	LENGTH 14'0"	LENGTH 14'0"	LENGTH 17'1"
381cm	426.7cm	426.7cm	426.7cm	518.1cm
WIDTH 26.0"	WIDTH 24.5"	WIDTH 26.0"	WIDTH 26.0"	WIDTH 25.0"
66.0cm	62.2cm	66.0cm	66.0cm	63.5cm
VOLUME 264L	VOLUME 278L	VOLUME 278L	VOLUME 295L	VOLUME 350L
WEIGHT 23.6Lbs	WEIGHT 23.5Lbs	WEIGHT 23.5Lbs	WEIGHT 26.5Lbs	WEIGHT 34Lbs
10.7KGS (+/- 10%)	10.7KGS (+/- 10%)	10.7KGS (+/- 10%)	12KGS (+/- 10%)	15.4KGS (+/- 10%)
MAX RIDER WEIGHT 168Lbs	MAX RIDER WEIGHT 168Lbs	MAX RIDER WEIGHT 168Lbs	MAX RIDER WEIGHT 192Lbs	MAX RIDER WEIGHT 250Lbs
89.8kgs	89.8kgs	89.8kgs	109.8kgs	113.4kgs
FIN SETUP: SINGLE 7.0" WEEDELES	FIN SETUP: SINGLE 7.0" WEEDELES	FIN SETUP: SINGLE 7.0" WEEDELES	FIN SETUP: SINGLE 7.0" WEEDELES	WITH FAST STEERING FIN SETUP: 3K 8.0" DAGGER (F.A.S.T)

DOWNWIND + TOUR

BULLET SERIES

DOWN WIND | PERFORMANCE FITNESS | TOURING

KEY FEATURES:

The Bullet 12'6" and 14'0" comes in SCC+ (Single Carbon Composite + Innegra™) and 14'0" also is offered in SCC+ with SIC's patent FAST (Foot Actuated Steering Technology). SCC+ combines a full wrap biaxial carbon fiber and Innegra™ reinforcement on the tip, tail and rails as well as an additional of biaxial glass rail reinforcement, 3mm high density PVC deck reinforcement and finished with a crocodile textured EVA deck pad, 12K carbon Weedless fin 7.0", EZ-Grab handle, bungee tie downs, leash plug, Gore-Tex™ breather vent, action camera mount on nose

The Bullet 11'0", 12'6" and 14'0" lengths also come in a SIC's extremely durable TWC (Tough Wood Carbon) and come equipped with a 12K carbon Weedless fin 7.0", crocodile textured EVA deck pad, EZ-Grab handle, bungee tie downs, leash plug, Gore-Tex™ breather vent, action camera mount on nose.

Bullet 17.4 DCC+ (Double Carbon Composite + Innegra™), which combines two layers of biaxial carbon fiber on both the top and bottom of the board and additional Innegra™ reinforcement on the tip, tail and rails. It is further reinforced with biaxial glass on the rails. This board comes equipped with F.A.S.T (3k carbon rudder), crocodile textured EVA deck pad, EZ-Grab carry handle, bungee tie downs, leash plug, Gore-Tex™ breather vent, action camera mount on nose

BULLET TECHNOLOGY

TUFF-WOOD CARBON

1. MOLDED BIAxIAL GLASS COMPOSITE
2. UNI-DIRECTIONAL CARBON RAIL STIFFENING/REINFORCEMENT
3. REINFORCED TUFF-WOOD DECK
4. LIGHT WEIGHT/MOLDED EPS CORE
5. GORE-TEX BREATHER VENT
6. EZ-GRAB CARRYING HANDLE



TWC
TUFF-WOOD CARBON

DOUBLE CARBON COMPOSITE + INNEGRA™

1. FULL WRAP UNI-DIRECTIONAL CARBON FIBER + FULL WRAP BIAxIAL CARBON FIBER
2. INNEGRA™ TIP, RAIL AND TAIL REINFORCEMENT
3. 2-LAYERS BIAxIAL GLASS RAIL REINFORCEMENT
4. LIGHT WEIGHT CNC/EPS CORE
5. GORE TEX BREATHER VENT
6. 3MM PVC DECK REINFORCEMENT
7. CROC TEXTURE EVA DECK PAD
8. EZ-GRAB HANDLE



DCC+
DOUBLE CARBON COMPOSITE
INNEGRA

SINGLE CARBON COMPOSITE + INNEGRA™

1. FULL WRAP BIAxIAL CARBON FIBER
2. INNEGRA™ TIP, RAIL AND TAIL REINFORCEMENT
3. 2-LAYERS BIAxIAL GLASS RAIL REINFORCEMENT
4. 3MM HIGH DENSITY PVC DECK REINFORCEMENT
5. CROCOTILE TEXTURED EVA DECK PAD
6. EZ-GRAB CARRYING HANDLE
7. LIGHT WEIGHT CNC/EPS CORE
8. GORE-TEX BREATHER VENT

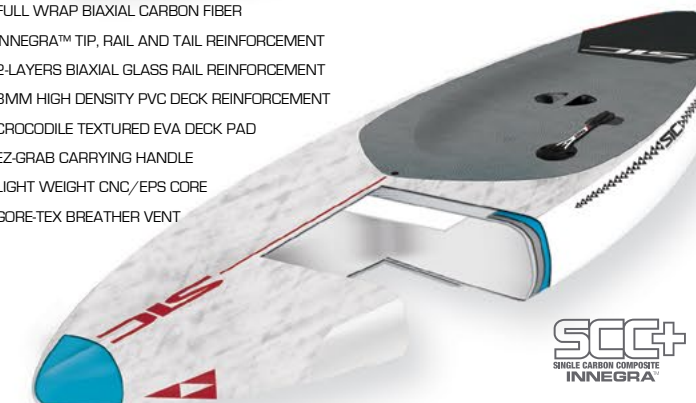

SCC+
SINGLE CARBON COMPOSITE
INNEGRA

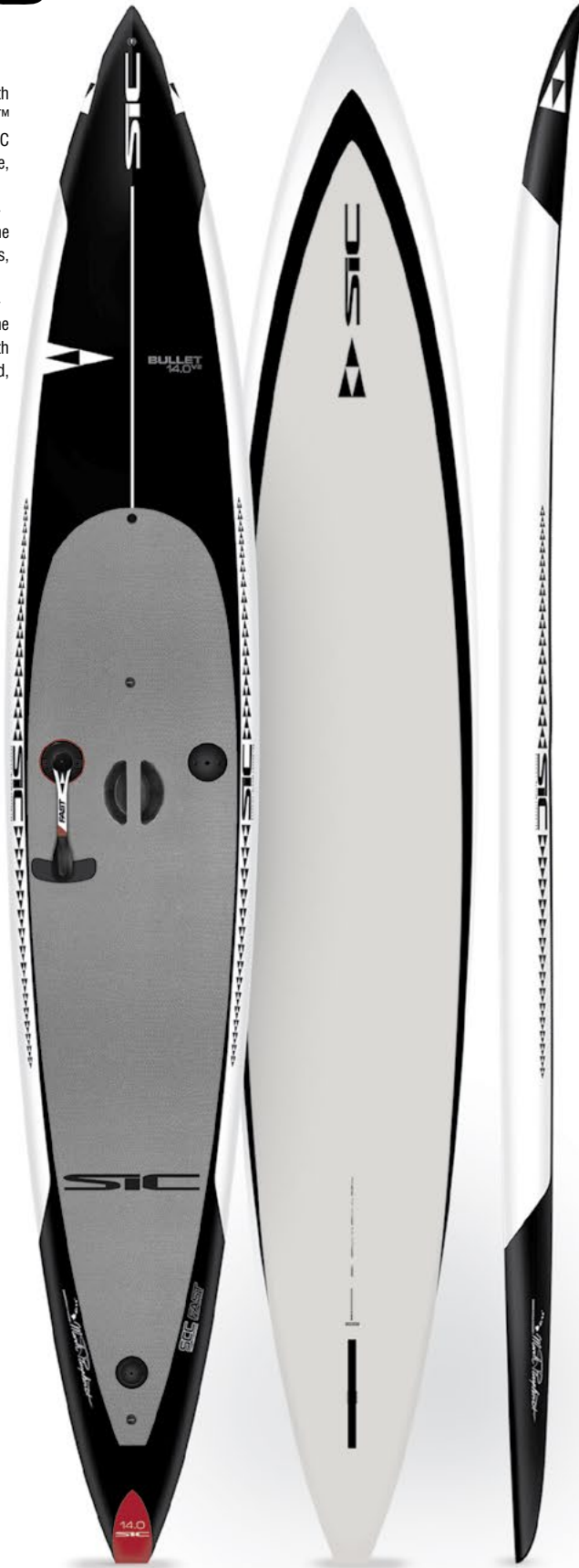

PERFORMANCE PROFILE:

The Bullet Series has become an icon. While its roots are in open water and down-winding the Bullet has proven that it can literally do it all. The Bullet series has gained a huge following from paddlers who love cruising, touring and fitness. Paddlers also rave about the Bullet's ability to surf extremely well. This board turns a small wave day into shred fest. Stable, fun, fast, the Bullet series has won numerous awards for its overall performance and versatility. Winning "Best Overall Board" twice in the SUP Connect Awards and has been awarded "Gear of The Year" by Outside Magazine. The Bullet features a flat bottom (planing hull) with a slight double concave finishing in a panel V design at the tail, which gives the board a very stable platform rail-to-rail and smooth glide through the water. The decking of the board features a lightly contoured shape in the standing area for increased control, minimizes foot cramping and encourages water drainage. Offered in SCC+ (Single Carbon Composite +Innegra™) or TWC (Tough Wood Carbon), These are the same shapes in a high-performance carbon or durable fiberglass carbon option.

17.4 PERFORMANCE PROFILE:

The Bullet 17'4" remains one of the most winning open water, channel cross-ing boards of all time. Not many can even come close with the exception of the new SIC Bayonet 17'1". Still the Bullet remains one of the fastest downwind boards in the world. The Bullet 17'4" is wider, more stable than the Bayonet and has a bit more rocker making it extremely fast and a bit more stable. The additional rocker makes it more forgiving than the Bayonet in a tight fetch, rough seas and steeper troughs. The Bullet surfs extremely well and will help fight leg fatigue in side chop. The Bullet 17'4", like the Bayonet 17'1", is constructed in DCC+ construction and is a proven, reliable and great choice for those looking to downwind for the fun of it and also has the speed and handling to podium in a race.

BULLET SPECIFICATIONS

						
TWC 11.0 LENGTH 11'0" 335.3cm	TWC 12.6 LENGTH 12'6" 381.0cm	SCC+ 12.6 LENGTH 12'6" 381.0cm	TWC 14.0 LENGTH 14'0" 426.7cm	SCC+ 14.0 LENGTH 14'0" 426.7cm	SCC+ 14.0 LENGTH 14'0" 426.7cm	SCC+ 17.4 LENGTH 17'4" 528.3cm
WIDTH 28.25" 71.8cm	WIDTH 28.25" 71.8cm	WIDTH 28.25" 71.8cm	WIDTH 27.25" 69.2cm	WIDTH 27.25" 69.2cm	WIDTH 27.25" 69.2cm	WIDTH 26.6" 67.6cm
VOLUME 208L	VOLUME 237L	VOLUME 237L	VOLUME 269L	VOLUME 269L	VOLUME 269L	VOLUME 370L
WEIGHT 26.7Lbs 12.1kgs (+/- 10%)	WEIGHT 30.2Lbs 13.7kgs (+/- 10%)	WEIGHT 24.3Lbs 11kgs (+/- 10%)	WEIGHT 31.3Lbs 14.2kgs (+/- 10%)	WEIGHT 27.0Lbs 12.3kgs (+/- 10%)	WEIGHT 29Lbs 13.2kgs (+/- 10%)	WEIGHT 36.8Lbs 16.6kgs (+/- 10%)
MAX RIDER WEIGHT 180Lbs 81.6kgs	MAX RIDER WEIGHT 200Lbs 90.7kgs	MAX RIDER WEIGHT 200Lbs 90.7kgs	MAX RIDER WEIGHT 245Lbs 111.1kgs	MAX RIDER WEIGHT 245Lbs 111.1kgs	MAX RIDER WEIGHT 245Lbs 111.1kgs	MAX RIDER WEIGHT 245Lbs 111.1kgs
FIN SETUP: SINGLE 7.0 WEEDELES	FIN SETUP: SINGLE 7.0 WEEDELES	FIN SETUP: SINGLE 7.0 WEEDELES	FIN SETUP: SINGLE 7.0 WEEDELES	FIN SETUP: SINGLE 7.0 WEEDELES	WITH FAST STEERING	WITH FAST STEERING

F SERIES

RECREATIONAL FITNESS / TOUR / RACE

PERFORMANCE PROFILE:

The F Series boards have garnered huge appreciation for its Bullet-like performance characteristics in generous widths making rough water cruising and down winding accessible to a wider range of paddler abilities and weights. Its flat bottom (planing hull), fuller rails and wider stabilizing tail add to the F's rail-to-rail stability. Built as a touring and fitness board ready to jump on a downwind run or drop into fun waves when the surf is up; for paddling in lakes, harbors or smaller bodies of water prone to the effects of boat chop, the stability of the F Series is optimal. The F Series boards provide the ability to focus on fundamentals because and not worry about falling off the board. The performance of this board remains at a high level and will give a novice paddler room to grow into a recreational expert. The F Series is offered in 12'6" GC (Glass Composite) construction and the 14'0" is offered in the SCC+ construction.

KEY FEATURES:

The F 12'0" comes in a very durable GC (Glass Composite) construction, 12K carbon Weedless fin 7.0", crocodile textured EVA deck pad, EZ-Grab handle, bungee tie, leash plug, Gore-Tex™ breather vent, action camera mount on nose.

The F 14'0" comes in a lightweight SCC+ (Single Carbon Composite + Innegra™), 12K carbon Weedless fin 8.3", crocodile textured EVA deck pad, EZ-Grab handle, bungee tie, leash plug, Gore-Tex™ breather vent, action camera mount on nose.

F TECHNOLOGY SINGLE CARBON COMPOSITE + INNEGRA™

1. FULL WRAP BIAXIAL CARBON FIBER
2. INNEGRA™ TIP, RAIL AND TAIL REINFORCEMENT
3. BIAXIAL GLASS RAIL REINFORCEMENT
4. HIGH DENSITY PVC DECK REINFORCEMENT
5. CROCODILE TEXTURED EVA DECK PAD
6. EZ-GRAB CARRYING HANDLE
7. LIGHT WEIGHT CNC/ EPS CORE
8. GORE-TEX BREATHER VENT

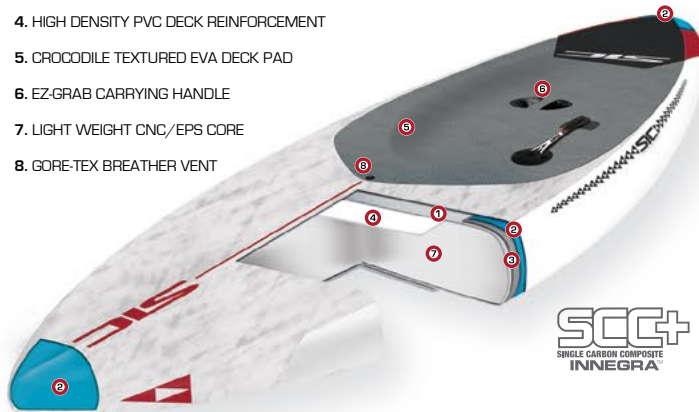

GLASS COMPOSITE

1. DOUBLE WRAP FIBERGLASS COMPOSITE
2. REINFORCED TUFF-WOOD DECK
3. LIGHT WEIGHT CNC/ EPS CORE
4. CROCODILE TEXTURED EVA DECK PAD
5. GORE-TEX BREATHER VENT
6. EZ-GRAB CARRYING HANDLE

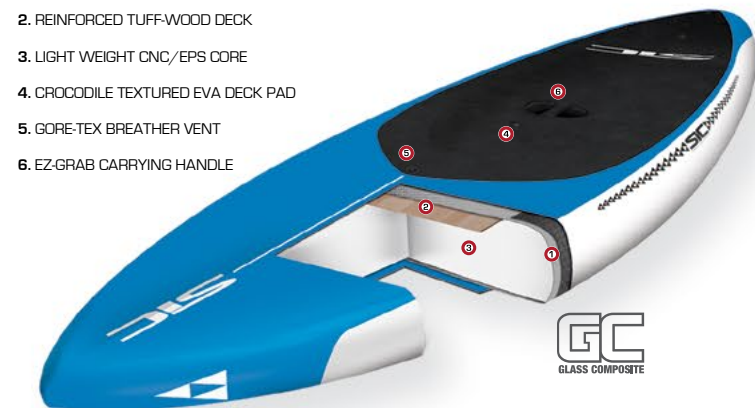

F SPECIFICATIONS



GC
12.0
LENGTH
12'0"
365.7cm
WIDTH
30"
76.2cm
VOLUME
265L
WEIGHT
28.2Lbs
12.8kgs (+/- 10%)
MAX RIDER
WEIGHT
245Lbs
111.1kgs

SCC+
14.0
LENGTH
14'0"
426.7cm
WIDTH
30"
76.2cm
VOLUME
298L
WEIGHT
28Lbs
12.7kgs (+/- 10%)
MAX RIDER
WEIGHT
275Lbs
124.7kgs

FIN SETUP: SINGLE 7.0 WEEDLES

FIN SETUP: SINGLE 8.3 WEEDLES

ALL NEW SERIES

SLICE PRO SERIES

PERFORMANCE SURF

PERFORMANCE PROFILE:

SIC has made plenty of SUP surf boards for its pros. Throughout the years we have come up with staple dimensions, which have more than satisfied our best surfers, and so without further ado we have extended the Slice Performance series into a Pro series. With lower volumes and more aggressive overall shapes, the Slice Pros are ready to rip! We are confident that these boards will put the stoke under the feet from the best soul surfer to those paddlers looking to compete at the highest level. A more advanced paddling ability is required for the Slice Pro, paddling while the board is submerged under the water's surface may be required and the ability to paddle continuously. These are truly designed for the accomplished or competitive SUP surfer. The Slice Pro is built in SIC's Glass Carbon Composite + Innegra™ (GCC+) construction

KEY FEATURES:

GCC+ (Glass Carbon Composite + Innegra™) which features a double wrap fiberglass composite layup, oak sandwich top, carbon reinforced standing area, co-mingled Carbon/Innegratm reinforced rails, 5 Fin (FCS2 compatible), diamond groove textured EVA deck pad and 4-piece kick pad, EZ-Grab handle, leash plug, Gore-Tex™ breather vent, action camera mount on nose

SLICE PRO TECHNOLOGY GLASS CARBON COMPOSITE + INNEGRA

1. DOUBLE WRAP FIBERGLASS COMPOSITE
2. OAK LAMINATE REINFORCED TOP
3. CARBON REINFORCED STANDING AREA
4. LIGHTWEIGHT CNC/EPS CORE
5. COMINGLED CARBON/INNEGRA REINFORCED RAILS / BOTTOM
6. DIAMOND GROOVED EVA DECK PAD
7. 4 PIECE, CUSTOM KICK PAD
8. ERGO UNDERCUT HANDLE

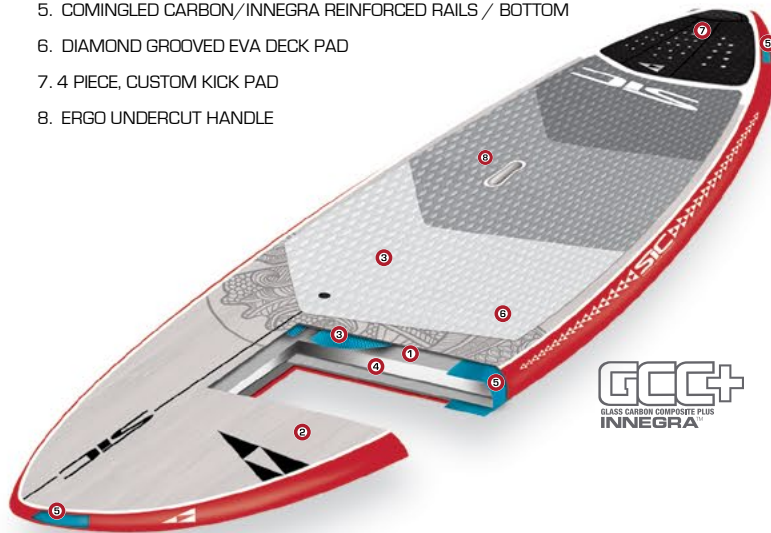

ALL NEW SERIES

SLICE PRO SPECIFICATIONS

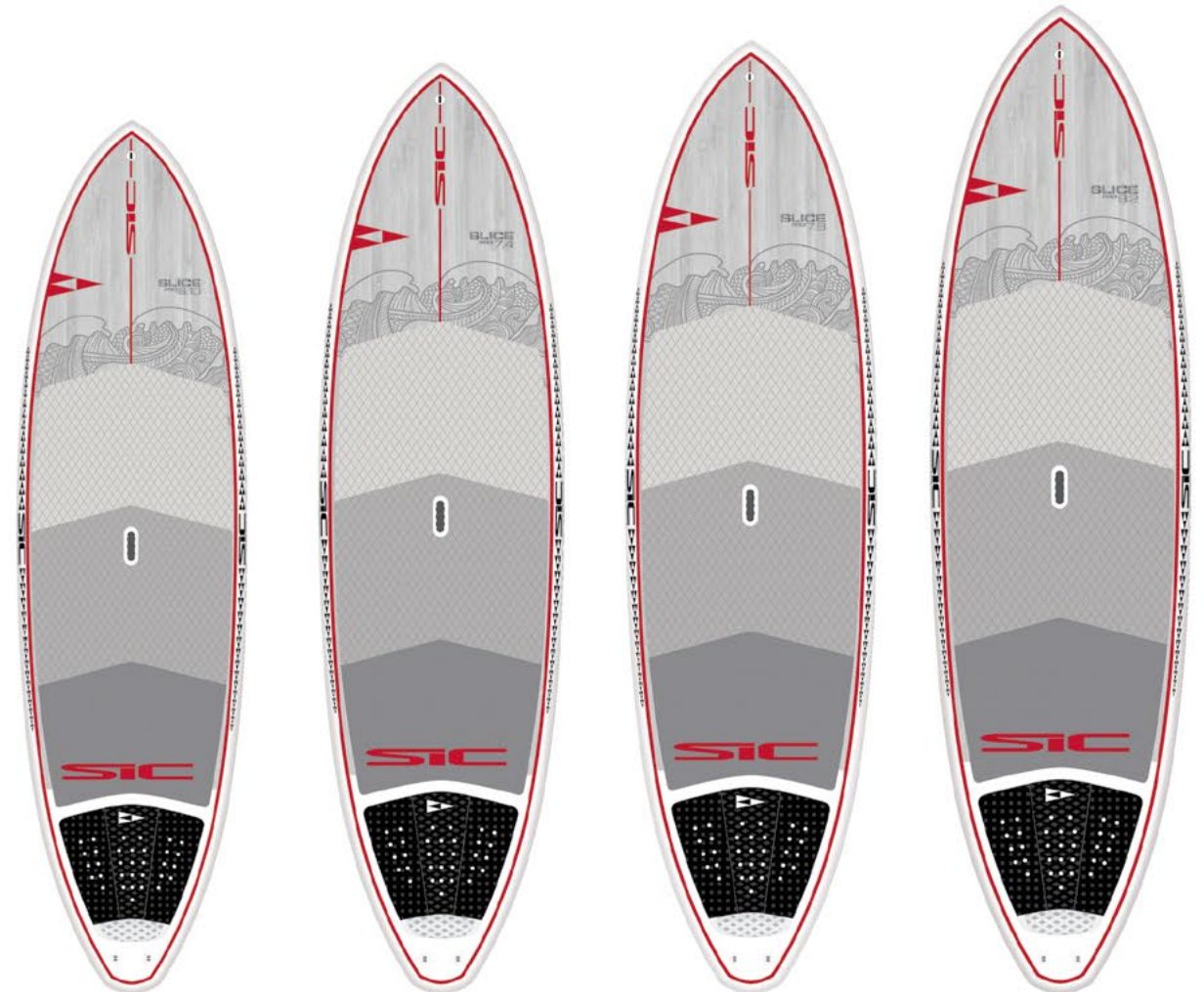

GCC+
6.10
LENGTH
6'10"
208.3cm
WIDTH
24.5"
62.3cm
VOLUME
72L
WEIGHT
15.2lbs
6.9kgs (+/- 10%)
MAX RIDER
WEIGHT
155lbs
70.3kgs

GCC+
7.4
LENGTH
7'4"
223.5cm
WIDTH
25.5"
64.8cm
VOLUME
85L
WEIGHT
15.9lbs
7.2kgs (+/- 10%)
MAX RIDER
WEIGHT
160lbs
73kgs

GCC+
7.8
LENGTH
7'8"
233.7cm
WIDTH
27.0"
68.6cm
VOLUME
95L
WEIGHT
17.0lbs
7.7kgs (+/- 10%)
MAX RIDER
WEIGHT
165lbs
74.8kgs

GCC+
8.2
LENGTH
8'2"
248.3cm
WIDTH
28.0"
71.1cm
VOLUME
110L
WEIGHT
18.1lbs
8.2kgs (+/- 10%)
MAX RIDER
WEIGHT
180lbs
81.6kgs

ALL NEW SERIES

SLICE SERIES

PERFORMANCE SURF

PERFORMANCE PROFILE:

The Slice is a totally new board for SIC. After making countless surf shapes and collecting feedback from riders around the world, these new board designs and dimensions have been studied, aggregated and now incorporated into a range of performance surf shapes for the rider just getting into SUP surf as well as advanced recreational and competition paddlers. Nothing was held back on the performance characteristics, so make no mistake, these boards rip. Not everyone has balance like a cat or can paddle with the board submerged to their knees, so we focused on stable shapes and volume distribution down the center line of the board giving you enough float to comfortably paddle out to the break and stand tall in the lineup. The rails have been profiled allowing you to edge into the face of the wave and slice through the water when powering through your turns. These boards are perfect for paddlers looking for stability without sacrificing performance. The Slice Performance is built in SIC's Glass Carbon Composite + Innegra™ (GCC+) construction.

KEY FEATURES:

GCC+ (Glass Carbon Composite + Innegra™) which features a double wrap fiberglass composite layup, oak laminate reinforced top and bottom, carbon reinforced standing area and full carbon bottom, comingled Carbon/Innegratm reinforced tip + tail + rails, 4+1 Fin (FCS2/U.S. Box compatible), diamond groove textured EVA deck pad and 4-piece kick pad, EZ-Grab handle, leash plug, Gore-Tex™ breather vent, action camera mount on nose

SLICE TECHNOLOGY GLASS CARBON COMPOSITE + INNEGRA

1. COMINGLED CARBON/INNEGRA REINFORCED TIP + TAIL + RAILS
2. OAK LAMINATE REINFORCED TOP AND BOTTOM
3. CARBON REINFORCED STANDING AREA AND BOTTOM STRINGER
4. LIGHTWEIGHT CNC/EPS CORE
5. DOUBLE WRAP FIBERGLASS COMPOSITE
6. DIAMOND GROOVED EVA DECK PAD
7. 4 PIECE, CUSTOM KICK PAD
8. ERGD UNDERCUT HANDLE

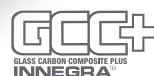
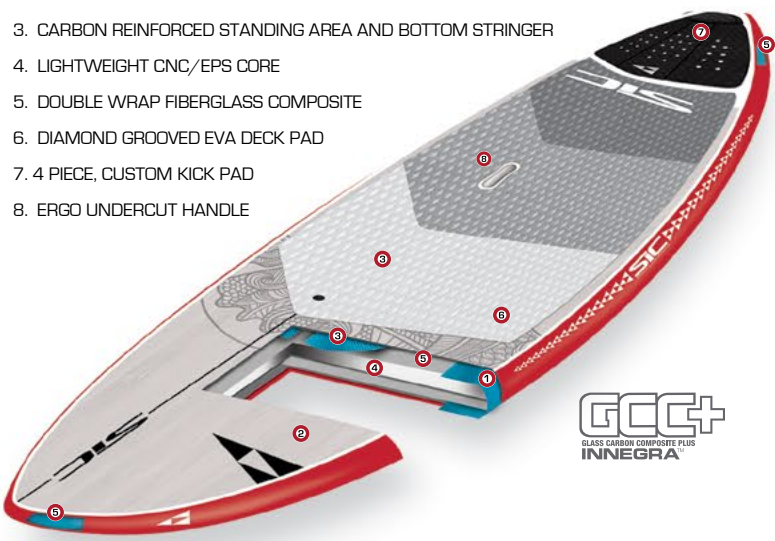

ALL NEW SERIES

SLICE SPECIFICATIONS

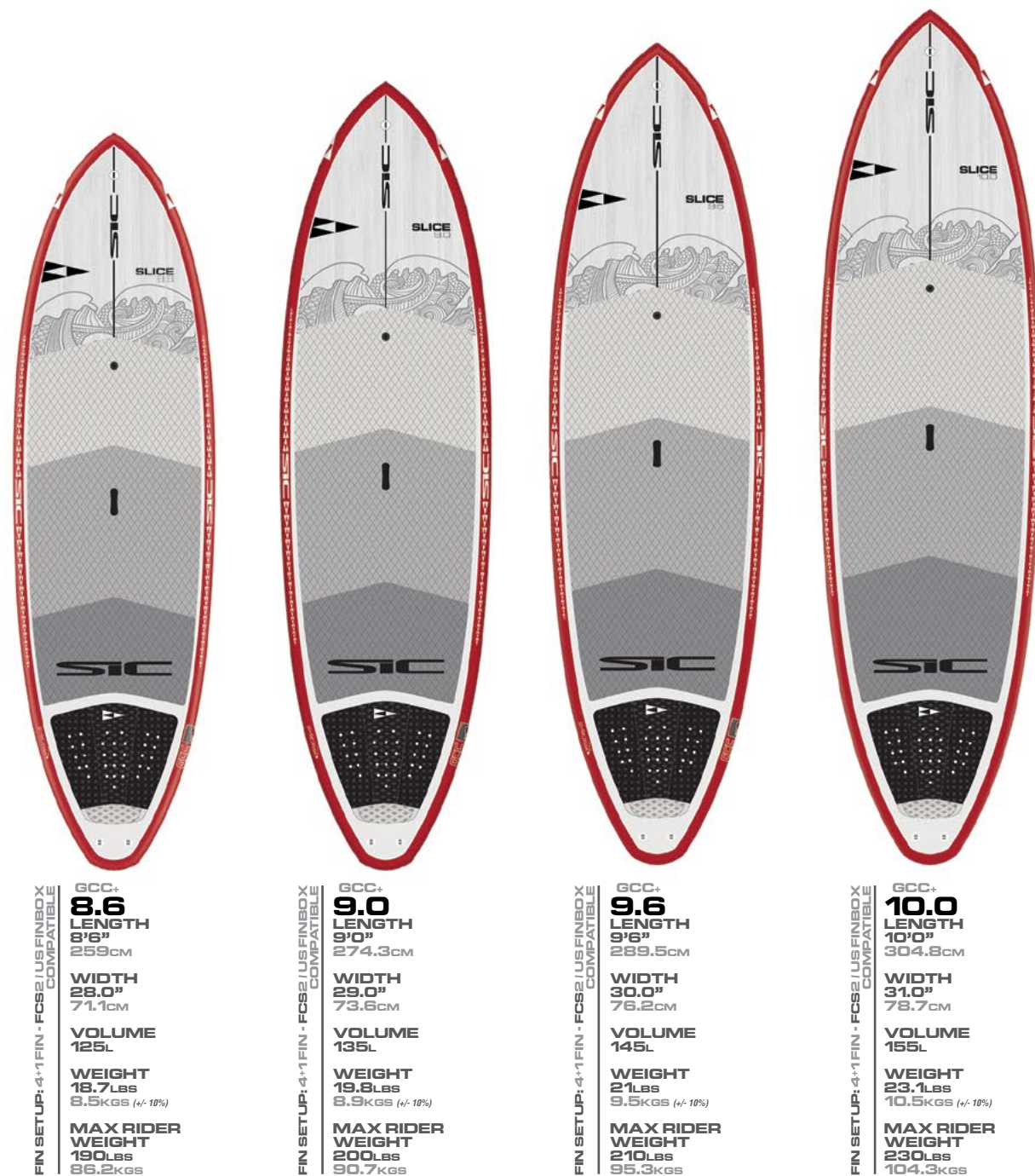

SURF + EXPLORE

ALL NEW SERIES

SABER SERIES

RECREATIONAL SURF / CRUISING / FITNESS

PERFORMANCE PROFILE:

We classify the Saber a surf/cruiser because when the surf comes up, the Saber will not let you down. These boards ride like a longboard, carry speed down the line and cruise effortlessly through the break and on the flats. The pinched rails and tail hip in the tail allow the board to carve smooth through turns keeping you smiling from ear-to-ear. This board is also designed as a stable recreational cruiser. Its flat bottom will give you the confidence you need in choppy waters and is perfect for cruising harbors, lakes or nearly anywhere you want to go. The Saber is built in SIC's Glass Composite + Innegra™ (GC+) construction which offers both performance and durability at an affordable price.

KEY FEATURES:

GC+ (Glass Composite + Innegra™) a double wrap fiberglass composite layup, oak laminate reinforced top, lightweight EPS core, Innegra™ tip, tail and rail reinforcement, 2 + 1 (FCS2/US Box compatible), diamond groove textured EVA deck pad and 4-piece kick pad, EZ-Grab handle, bungee tie downs, leash plug, Gore-Tex™ breather vent, action camera mount on nose

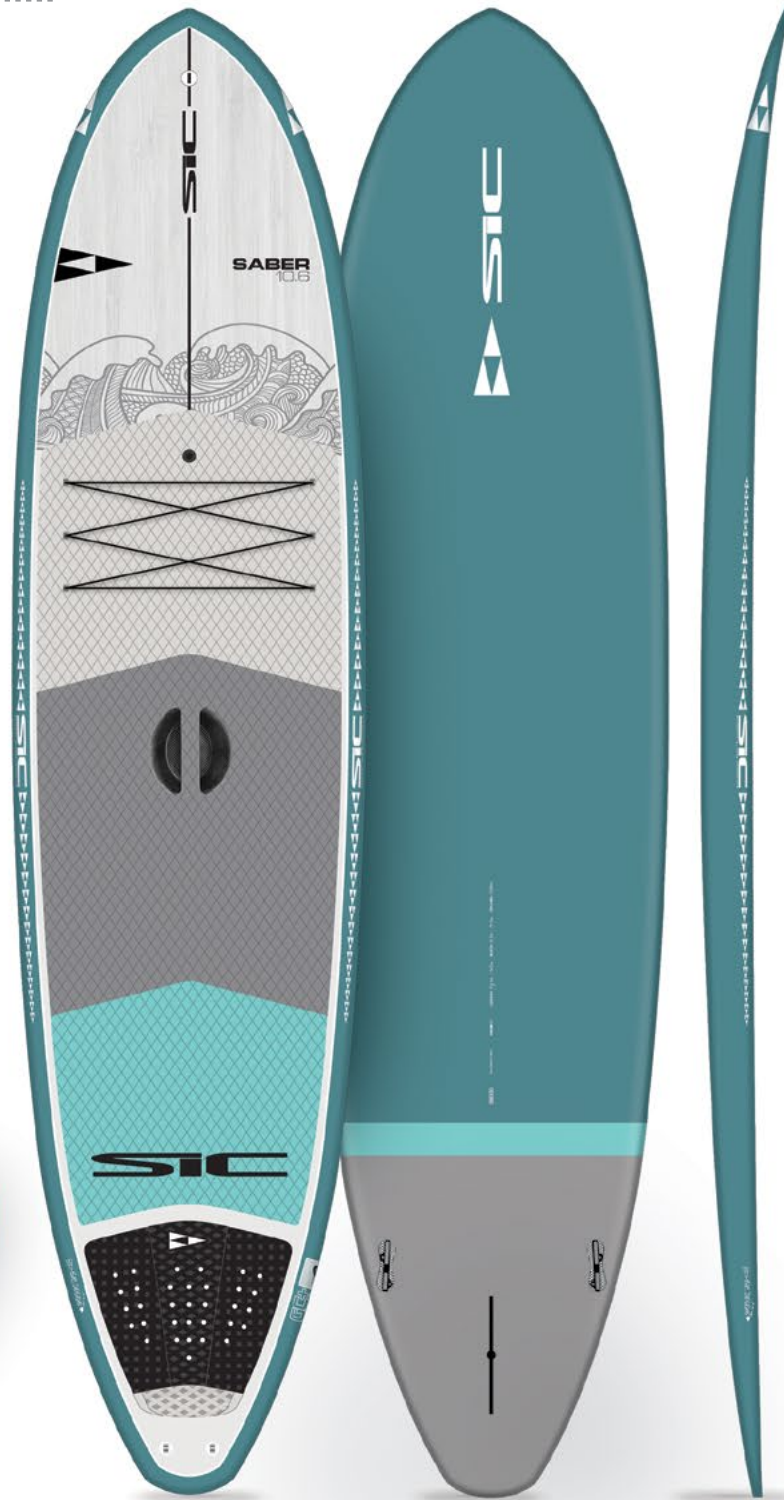

SABER TECHNOLOGY GLASS COMPOSITE + INNEGRA™

1. DOUBLE WRAP FIBERGLASS COMPOSITE
2. OAK LAMINATE REINFORCED TOP AND BOTTOM
3. LIGHTWEIGHT CNC/EPS CORE
4. INNEGRA™ TIP, RAIL AND TAIL REINFORCEMENT
5. DIAMOND GROOVED EVA DECKPAD
6. 4 PIECE, CUSTOM KICK PAD
7. EZ-GRAB CARRYING HANDLE

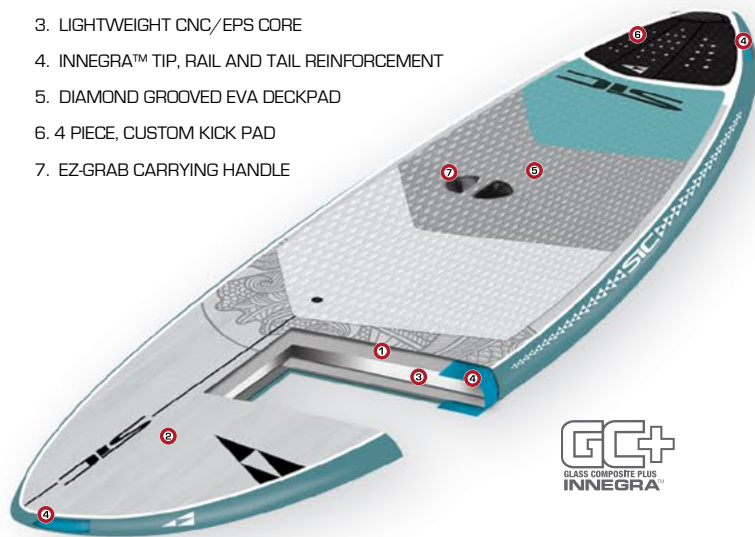

ALL NEW SERIES

SABER SPECIFICATIONS

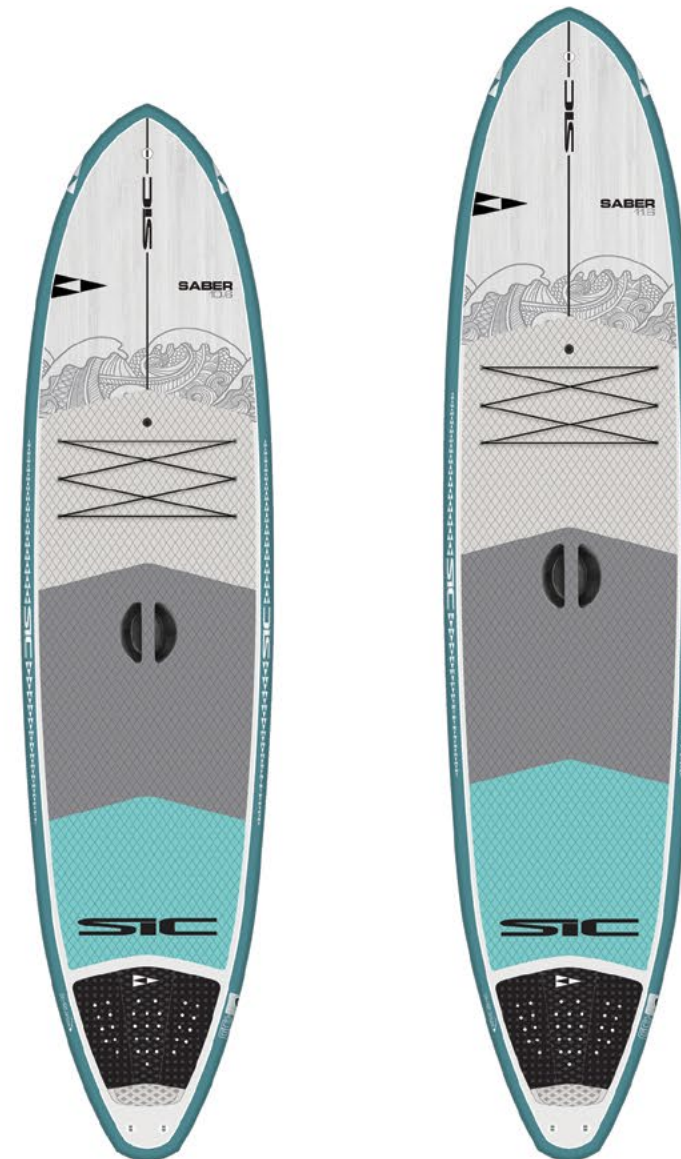

FIN SETUP: 2+1 FIN • FCS2 / US BOX COMPATIBLE

GC+ 10.6
LENGTH
 10'6"
 320cm

WIDTH
 30.0"
 76.2cm

VOLUME
 155L

WEIGHT
 24LBS
 10.9KGS (+/- 10%)

MAX RIDER WEIGHT
 210LBS
 95.3KGS

FIN SETUP: 2+1 FIN • FCS2 / US BOX COMPATIBLE

GC+ 11.6
LENGTH
 11'6"
 350.5cm

WIDTH
 30.0"
 76.2cm

VOLUME
 185L

WEIGHT
 26.5LBS
 12.0KGS (+/- 10%)

MAX RIDER WEIGHT
 230LBS
 104.3KGS

TAO SERIES

DURABLE SURF / FITNESS / CRUISING TOURING

PERFORMANCE PROFILE:

The TAO Surf and TAO ART series are inspired by traditional surf design. The full nose and rounded pintail help you to drop into waves, carving down the line with ease. The wider widths make the board stable, which comes in handy when punching through the shore break or standing out in the lineup. These boards also make for nice cruising boards with a moderate rocker line which tracks and glides nicely through the water. TAO boards can run multiple fin configurations (single fin or thruster setup). The overall volume is designed to accommodate the whole family, small or large. ST (Space Tec) construction offers a unique combination of durability performance at an affordable price. The ST (Space Tec) thermoformed construction technology produces lightweight, high-performance boards with exceptional durability and exact shapes.

ART SERIES:

The TAO ART series is part of SIC's "ART Series" boards which utilize a proprietary digital direct printed graphic on the polymer skin. It delivers both beauty and durability simultaneously. Each substrate is first printed with a unique design and then thermo-formed over the fiberglass skin. The art is UV stable and scratch resistant. This process allows SIC the flexibility to add durable art that will last for years.

KEY FEATURES:

ST (Space Tec) construction, which utilizes a polymer outer skin for impact resistance which is then thermo-formed over fiberglass and a closed cell EPS core for incredible durability. Digitally direct printed graphics, 2+1 fin set, smooth textured EVA pad for maximum comfort and no slip grip, Ergo-Undercut handle, bungee tie downs, leash plug

TAO TECHNOLOGY SPACE TECH



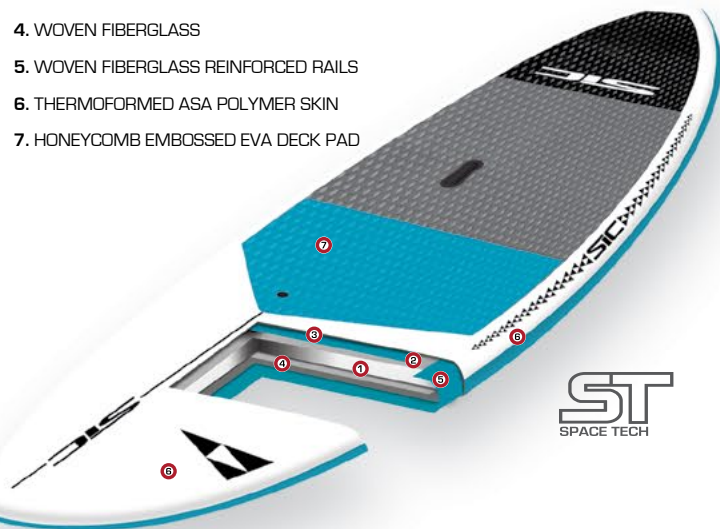

1. MOLDED, WATERTIGHT EPS FOAM CORE
2. FIBERGLASS WRAP
3. WOVEN FIBERGLASS REINFORCEMENT PATCH
4. WOVEN FIBERGLASS
5. WOVEN FIBERGLASS REINFORCED RAILS
6. THERMOFORMED ASA POLYMER SKIN
7. HONEYCOMB EMBOSSED EVA DECK PAD



ST
SPACE TECH

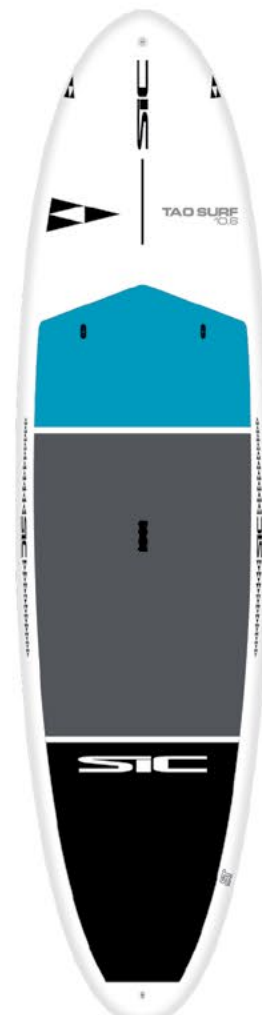

ALL NEW SERIES
TAO SPECIFICATIONS

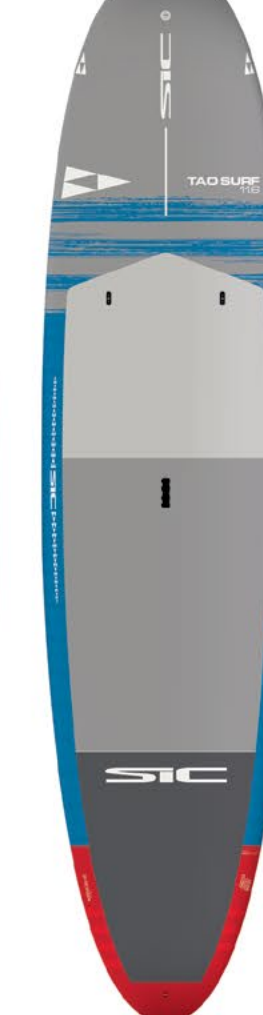
 <p>ST 10.6 LENGTH 10'6" 320cm</p> <p>WIDTH 31.5" 80cm</p> <p>VOLUME 185L</p> <p>WEIGHT 26LBS 12KGS (+/- 10%)</p> <p>MAX RIDER WEIGHT 200LBS 90KGS</p>	 <p>ST 11.6 LENGTH 11'6" 350cm</p> <p>WIDTH 32.5" 82cm</p> <p>VOLUME 215L</p> <p>WEIGHT 30LBS 13.5KGS (+/- 10%)</p> <p>MAX RIDER WEIGHT 240LBS 110KGS</p>	<p>NEW PRINTED ART SERIES FIN SETUP: 40" DOLPHIN + FCS COMPATIBLE SIDE FINS</p>  <p>ST 9.2 LENGTH 9'2" 280cm</p> <p>WIDTH 31.5" 80.0cm</p> <p>VOLUME 145L</p> <p>WEIGHT 24LBS 11KGS (+/- 10%)</p> <p>MAX RIDER WEIGHT 180LBS 80KGS</p>	<p>NEW PRINTED ART SERIES FIN SETUP: 40" DOLPHIN + FCS COMPATIBLE SIDE FINS</p>  <p>ST 10.6 LENGTH 10'6" 320cm</p> <p>WIDTH 31.5" 80.0cm</p> <p>VOLUME 185L</p> <p>WEIGHT 26LBS 12KGS (+/- 10%)</p> <p>MAX RIDER WEIGHT 200LBS 90KGS</p>	<p>NEW PRINTED ART SERIES FIN SETUP: 40" DOLPHIN + FCS COMPATIBLE SIDE FINS</p>  <p>ST 11.6 LENGTH 11'6" 350cm</p> <p>WIDTH 32.5" 82cm</p> <p>VOLUME 215L</p> <p>WEIGHT 30LBS 13.5KGS (+/- 10%)</p> <p>MAX RIDER WEIGHT 240LBS 110KGS</p>
--	---	---	---	--

SAGE SERIES

FITNESS | CRUISING | EXPLORING | FISHING

PERFORMANCE PROFILE:

For first-timers to families, fitness buffs, fishing and yogi's, the Sage series is designed to inspire confidence and deliver performance for a wide range of SUP disciplines, paddler abilities, styles and of any shape or size including beginners up to 350 pounds. With a flat deck area and multiple deck attachment points it's easy to customize the board for your intended use. With a generous 34" wide and 230L volume you will experience superior stability and gain confidence in your paddling ability. The hybrid hull is derived by combining a unique keeled nose design and flat mid to tail section. This gives the board its tremendous stability, tracking capability and glide efficiency. The Sage embodies lightweight performance allowing you to take your paddling to new places. The Sage is built in SIC's Glass Composite + Innegra™ (GC+) construction giving a lightweight feel without sacrificing durability.

KEY FEATURES:

GC+ (Glass Composite + Innegra™), which features a double wrap fiberglass composite layup, oak laminate reinforced top deck, lightweight EPS core, Innegra™ tip, tail and rails reinforcement, 2 + 1 (FCS2/US Box compatible), smooth textured EVA deck pad for maximum comfort and no slip grip, EZ-Grab handle, bungee tie downs, leash plug, Gore-Tex™ breather vent, action camera mount on nose

SAGE TECHNOLOGY GLASS COMPOSITE + INNEGRA™

1. DOUBLE WRAP FIBERGLASS COMPOSITE
2. OAK LAMINATE REINFORCED TOP AND BOTTOM
3. LIGHTWEIGHT CNC/EPS CORE
4. INNEGRA™ TIP, RAIL AND TAIL REINFORCEMENT
5. EVA DECKPAD
6. 4 PIECE, CUSTOM KICK PAD
7. EZ-GRAB CARRYING HANDLE

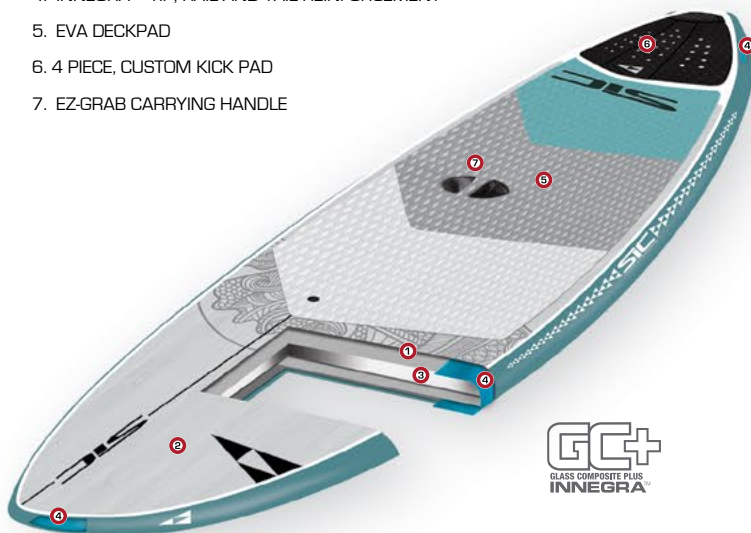

ALL NEW MODEL

SAGE SPECIFICATIONS



ALL NEW MODEL
FIN SETUP: SINGLE FCS 2 / US BOX COMPATIBLE

GC+
LENGTH
10'6"
320cm

WIDTH
34.0"
86.3cm

VOLUME
230L

WEIGHT
27.6Lbs
12.5kgs (+/- 10%)

MAX RIDER WEIGHT
220Lbs
100kgs

TAO FIT / BIG FISH SERIES

DURABLE SURF / FITNESS / CRUISING / TOURING

PERFORMANCE PROFILE:

The TAO Fit and TAO Big Fish are all about stability, durability and versatility. Whether paddling in slop and boat chop or taking a board down a section of fast water. The hybrid hull offers a unique keeled nose for cutting through chop and softening the ride while giving the board great tracking characteristics. The keeled nose transitions to flat throughout the middle of the board giving this board its outstanding stability. The flat deck offers the perfect platform for those looking for a board for yoga class or for the angler who wants to land the big one. A flat deck is also the perfect surface to keep your cooler, take your child or your dog for ride. All TAO Series boards feature SIC's proprietary ST (Space Tec) construction for unprecedented durability.

KEY FEATURES:

ST (Space Tec) construction, which utilizes a polymer outer skin for impact resistance, and incredible durability, full length smooth textured EVA deck pad for maximum comfort and no slip grip, 9.0" FCS Connect touring fin (nylon), Ergo-Undercut handle, bungee tie downs, leash plug. The Big Fish also has an additional channel system for mounting your fishing stands, electronic equipment or any other items you want to take along on your outing.

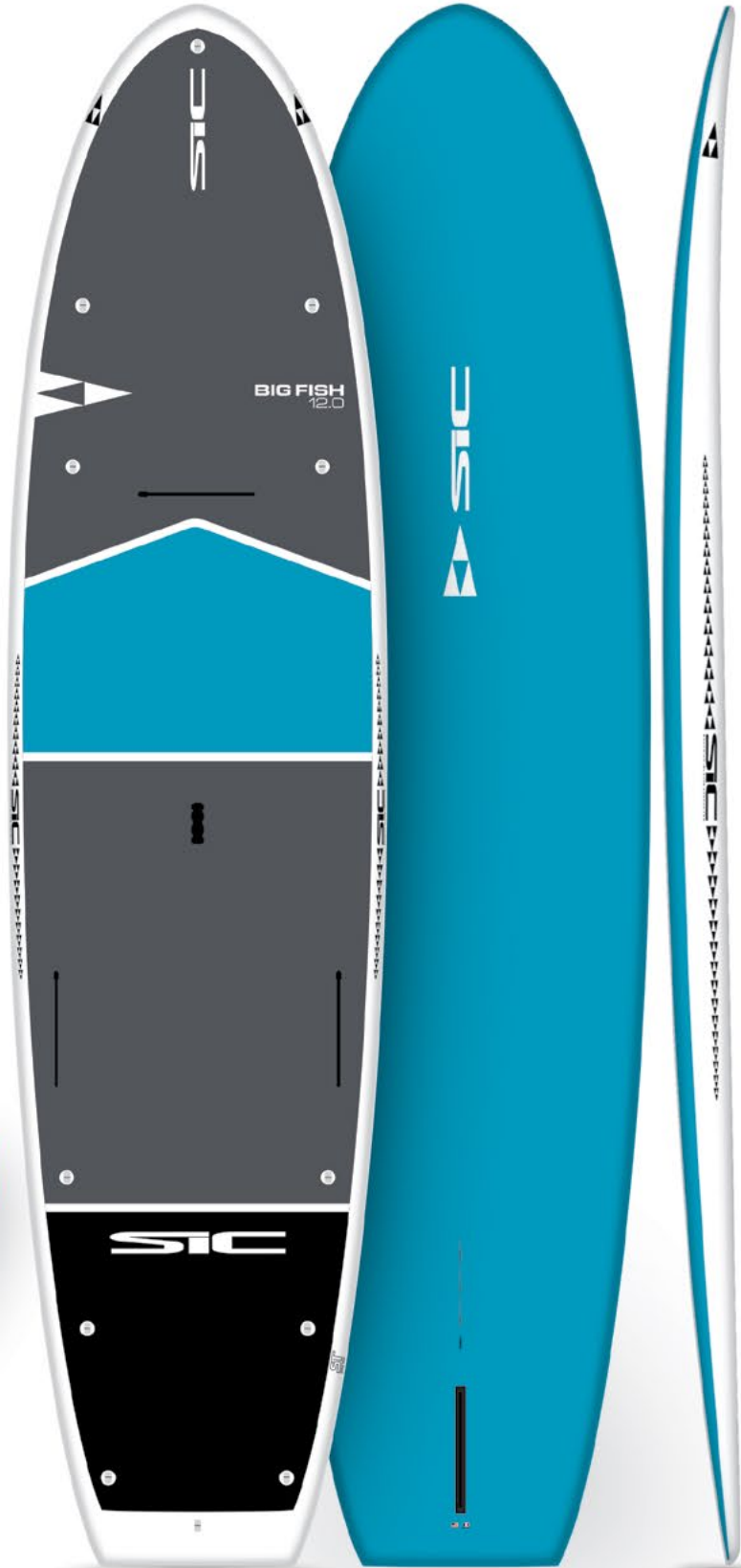

TAO TECHNOLOGY SPACE TECH

1. MOLDED, WATERTIGHT EPS FOAM CORE
2. FIBERGLASS WRAP
3. WOVEN FIBERGLASS REINFORCEMENT PATCH
4. WOVEN FIBERGLASS
5. WOVEN FIBERGLASS REINFORCED RAILS
6. THERMOFORMED ASA POLYMER SKIN
7. HONEYCOMB EMBOSSED EVA DECK PAD

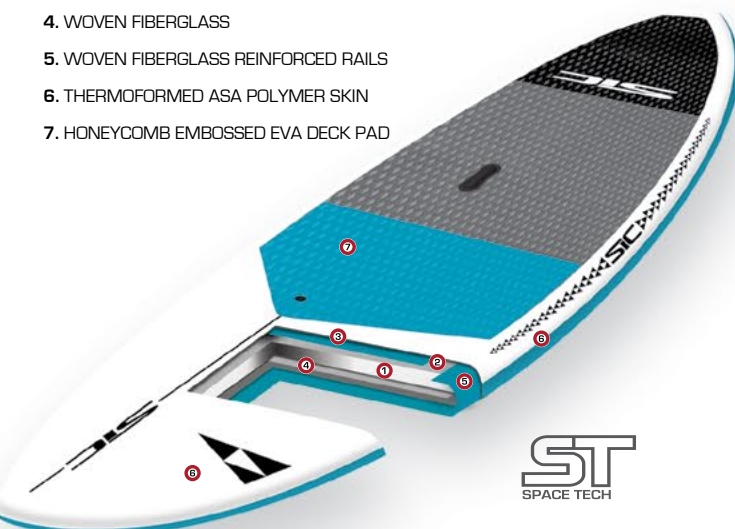

TAO FIT / BIG FISH SPECIFICATIONS



FIN SETUP: 9.0 FCS CONNECT TOURING FIN (NYLON)

ST
10.0
 LENGTH
 10'0"
 305cm

WIDTH
 33.0"
 84cm

VOLUME
 195L

WEIGHT
 28LBS
 13kgs (+/- 10%)

MAX RIDER WEIGHT
 220LBS
 100kgs

FIN SETUP: 9.0 FCS CONNECT TOURING FIN (NYLON)

ST
11.0
 LENGTH
 11'0"
 335cm

WIDTH
 34.0"
 86cm

VOLUME
 260L

WEIGHT
 35LBS
 16kgs (+/- 10%)

MAX RIDER WEIGHT
 285LBS
 130kgs

FIN SETUP: 9.0 FCS CONNECT TOURING FIN (NYLON)

ST
12.0
 LENGTH
 12'0"
 366cm

WIDTH
 35.0"
 89cm

VOLUME
 350L

WEIGHT
 49LBS
 22kgs (+/- 10%)

MAX RIDER WEIGHT
 350LBS
 160kgs

INFLATABLE

AIR-GLIDE SERIES

INFLATABLE:
RACE + TOUR / DOWNWIND + TOUR / SURF + EXPLORE

KEY FEATURES:

SST (Single Skin Technology), 8.0" Mahi fin (nylon), 2 integrated side carry handles and shoulder carry strap, smooth textured EVA deck pad for maximum comfort and no slip grip, Flush center carry handle, tethering and leash D-rings on nose and tail, bungee tie downs on nose and tail, dual action pump, leash, wheelie backpack and repair kit. All boards come equipped with Air7 polycarbonate fin box which is stiffer and stronger and is easier to repair. Its low profile design reduces drag and makes you go faster.

KEY FEATURES:

FST (Fusion Skin Technology) is the best material to build an inflatable, offering the stiffest board at the lowest possible weight at 15-20 psi, 9.0" Weedless fin (nylon), diamond grooved EVA deck pad, 2 integrated race handles, center carry handle, bungee tie downs, dual action pump, leash, wheelie backpack and repair kit with spare fin plates. All boards come equipped with Air7 polycarbonate fin box which is stiffer and stronger and is easier to repair. Its low profile design reduces drag and makes you go faster.

AIR-GLIDE TECHNOLOGY STRINGER SUPPORT TECHNOLOGY

1. SINGLE SKIN TECHNOLOGY (SST)
2. DURABLE LIGHT WEIGHT DROP STITCH FIBERS (DSC)
3. DOUBLE SIDEWALL CONSTRUCTION (DSW)
4. HEX DEBOSS PATTERN EVA DECK PAD
5. COMFORT AIR-GLIDE HANDLE
6. SHOULDER CARRY STRAP
7. CARRY HANDLES ON RAILS, NOSE, TAIL
8. YOGA PADDLE HOLDER LOOPS
9. STAINLESS STEEL SURF LEASH LOOP
10. HIGH PRESSURE AIR VALVE
11. CARGO NET ON NOSE AND TAIL
12. UNIVERSAL US FINBOX

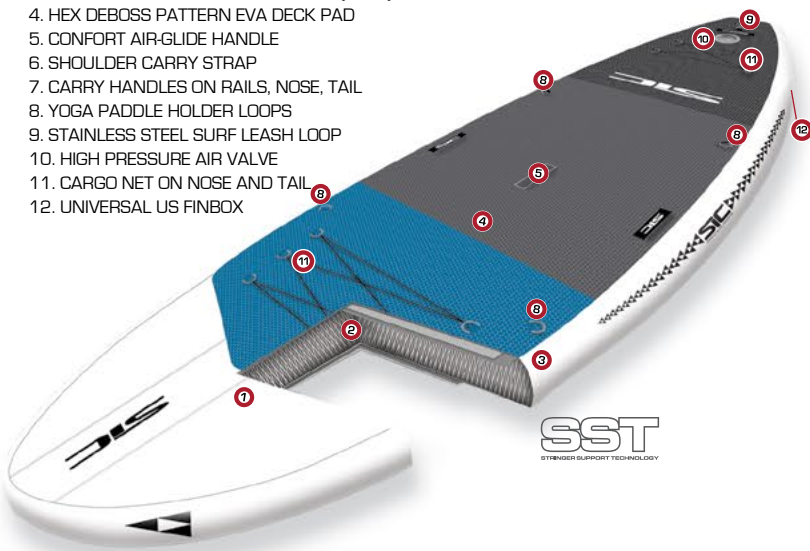

SST
STRONGER SUPPORT TECHNOLOGY

FUSION SKIN TECHNOLOGY

1. FUSION SKIN TECHNOLOGY (FST)
2. HIGH TENSILE DROP STITCH FIBERS (DSC)
3. DOUBLE SIDEWALL CONSTRUCTION (DSW)
4. DIAMOND GROOVED EVA DECK PAD
5. COMFORT AIR-GLIDE HANDLE
6. STAINLESS STEEL SURF LEASH LOOP
7. HIGH PRESSURE AIR VALVE
8. UNIVERSAL US FIN BOX SYSTEM
9. CARGO NET

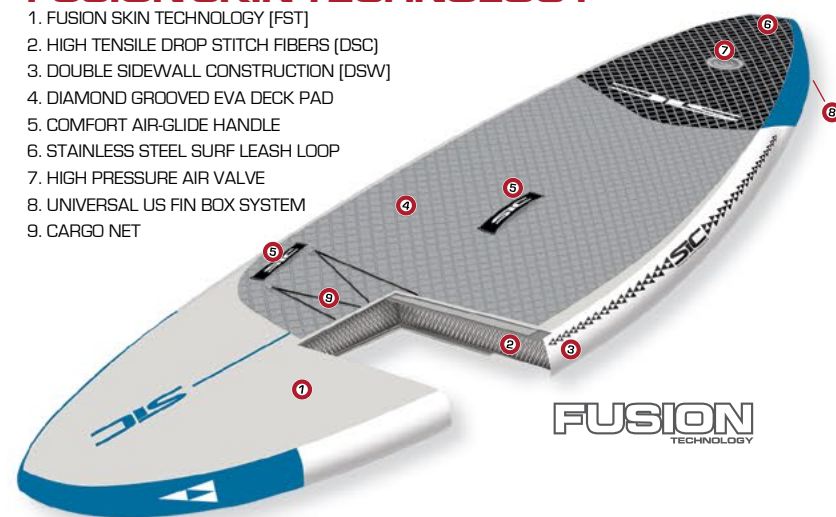

FUSION
TECHNOLOGY



PERFORMANCE PROFILES:

AIR-GLIDE TAO FIT

The TAO Fit is designed specifically for the paddler who wants a board to take out for a cruise or into a SUP yoga class. It has been specifically adapted based on the experience and input of Seychelle, who is not only an elite racer on SIC's global race team, but also an accomplished wellness, SUP yoga / fitness instructor. The features on this board are derived from her years of teaching and testing. From her learnings, we have designed the TAO Fit to create the ideal board for paddlers and fitness folks alike. Made from the Finest Drop Stich construction (DSC) and lightweight and durable Single Skin Technology (SST) these boards are light, stiff reliable.

AIR-GLIDE / RS:

The RS Air-Glide series derives its shape and dimensions from the new RS composite boards and translates to the highest performance inflatables on the market. This means proven designs inspire the SIC's Air-Glide inflatable boards for unrivaled performance and convenience. As the inflatable fitness, cruising and racing demand have grown within the inflatable class of boards, SIC has continued to innovate and serve up best technology and performance in an inflatable board. These all-water, multi-discipline, shapes are versatile, convenient and yet offer performance that will not deflate your ego or compromise your experience. SIC's materials selection, shapes and constructions dictate performance and prove that not all inflatables are created equal. Made from the finest Drop Stich Construction (DSC) and Fusion Skin Technology (FST) these boards are light, stiff and fast.

AIR-GLIDE / BULLET:

Not everyone has the space to store a 14 foot+ paddle board or a vehicle to transport a 14-footer, let alone a 17-foot board, but that shouldn't keep you from owning one. With the Bullet Air-Glide inflatable now anyone has access to the beach and a high-performance board. Made from the Finest Drop Stich Construction (DSC) and the stiffest Fusion Skin Technology (FST) these boards are light, stiff and fast. They are great for adventure and fitness paddling and designed after their composite counter-part (the Bullet composite) so they are ready to drop in and power up on the windier days for those looking for a compact downwind board. Don't let your tiny spaces keep you from the vastness of the open water.

AIR-GLIDE SPECIFICATIONS

AIR-GLIDE TAO MODEL

AIR-GLIDE RS SERIES

AIR-GLIDE BULLET SERIES

Model	Length	Width	Volume	Weight	Max Rider Weight
AIR-GLIDE TAO MODEL					
SST 10.6	10'6"	33.0"	305L	23.5Lbs 11kgs (+/- 10%)	220Lbs 100kgs
AIR-GLIDE RS SERIES					
FST 11.0	11'0"	24.0"	230L	18.7Lbs 8.5kgs (+/- 10%)	165Lbs 74.8kgs
FST 12.6	12'6"	29.0"	320L	24.7Lbs 11.2kgs (+/- 10%)	230Lbs 104.3kgs
AIR-GLIDE BULLET SERIES					
FST 14.0	14'0"	26.0"	320L	24.7Lbs 11.2kgs (+/- 10%)	220Lbs 100kgs
FST 14.0	14'0"	28.0"	350L	26.9Lbs 12.2kgs (+/- 10%)	240Lbs 108.9kgs
FST 14.0	14'0"	28.5"	340L	25.4Lbs 11.5kgs (+/- 10%)	240Lbs 108.9kgs
FST 17.4	17'4"	26.6"	420L	28.7Lbs 13kgs (+/- 10%)	230Lbs 104.3kgs

ALL NEW SERIES

SURF SERIES

DURABLE SURF

PERFORMANCE PROFILE:

SIC's believes we are all "Bound by Water™". Whether we are from different countries, cultures and socio-economic backgrounds; we are all connected in some way by water. If water is our common thread then paddle boarders, outrigger paddlers, surfers, foilers, kites, windsurfers are all connected and often thrive in the water regardless of what type of vessel they chose to utilize. In fact, SIC is truly a product of all these different disciplines. From the diverse water sport experience of SIC's Founder and Head Designer Mark Raaphorst to the team, staff, friends and family we are driven to be in the water and have fun regardless of the craft we on which we choose to play.

SIC set is driven to be more than a great paddle board company. SIC is driven to be the best water sports company it can be. We are driven to share our love for the water with others and bring new people into these sports.

As an innovator, SIC wants to bring great technology, performance and fun to customers regardless of what they are doing. Many people who paddle are not just paddlers, they enjoy a multitude of water and non-water sports and activities as well. It is our belief and commitment to bring best-in-class products from premium performance to recreational fun. It is with this in mind, that we are introducing a range of Space Tec thermo-form constructed surf shapes as well as a range of performance soft boards using Vortex™ construction to our product offering.

We hope that you enjoy these innovative new products that offer durable surf performance at a great price.

KEY FEATURES:

Digitally direct printed graphics to delivery both beauty and durability, ST (Space Tec) construction, utilizes a polymer outer skin for impact resistance which is then thermo-formed over fiberglass and a closed cell EPS core for incredible durability, leash plug, Thruster Tri Fin (FCS M5 Thrusters)

TECHNOLOGY SPACE TECH

1. MOLDED, WATERTIGHT EPS FOAM CORE
2. WOVEN FIBERGLASS REINFORCEMENT PATCH
3. WOVEN FIBERGLASS REINFORCED RAILS
4. HONEYCOMB EMBOSSED EVA DECK PAD
5. THERMOFORMED ASA POLYMER SKIN
6. WOVEN FIBERGLASS
7. FIBERGLASS WRAP

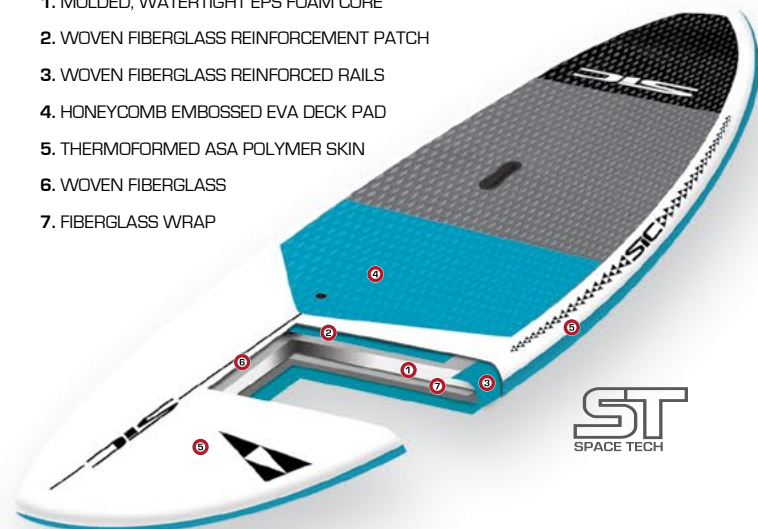

ST
SPACE TECH



CARVER:

Combining that elusive blend of versatility and performance with unbeatable durability. The 7'6" Carver lives up to its name! Possessing the stability and ease of a longboard with integral design elements of a quick-turning shortboard. The Carver offers you the chance to pump up your surfing technique while decreasing your board length. Able to surf in a wide range of wave conditions, the Carver will give you endless fun and a versatile, fun ride on these proven shapes.

LONGBOARD:

Handling both small waves and pumping swell with style, the Classic Longboard offers both beginners and seasoned surfers a ride with endless possibilities. If you are looking to hang ten, get tubed or perform a roundhouse cutback, the Classic Longboard will deliver. Effortlessly bringing together modern technology with old-school style, this longboard will satisfy surfers of all levels. Beginners will appreciate its volume and a forgiving outline, while advanced wave walkers will be impressed with the way it handles in pumped-up swell. These boards hold a high-line and will keep you nicely in the pocket. Built with the durable ST (Space Tec) construction, the Classic Longboard will last you many years and through thousands of great surf sessions!

NOSERIDER:

Designed by the legendary shaper Darrell Rooster Dell, this 9'4" Noserider is focused on a traditional, old school, style of longboarding. Particularly suited for mid to heavy weight riders the 9'4 has good volume for easy take-offs and stable noserider characteristics favoring speed and easy rail-to-rail transitions. A versatile board that is will suit classic surfers and newer surfers who favor classic riding style and performance.

BIG BOY:

The SIC Big Boy is a higher-volume longboard style surfboard designed to be either a stable platform for newer surfers and yet provides a performance surf for the more experienced, fuller body surfers. This board allows you to get into the wave early, transitions nicely rail to rail and carves well through your turns. It is durable and fun for the whole family.



FIN SETUP: U.S. FINBOX + SIDE FINS (FCS B + FCS GL)
ST 7.6
LENGTH
 7'6"
 228cm
WIDTH
 21.4"
 54cm
VOLUME
 51L
WEIGHT
 12.5Lbs
 5.7KGS (+/- 10%)
MAX RIDER WEIGHT
 187Lbs
 85KGS



FIN SETUP: U.S. FINBOX + SIDE FINS (FCS B + FCS GL)
ST 9.0
LENGTH
 9'0"
 276cm
WIDTH
 22.5"
 57cm
VOLUME
 66L
WEIGHT
 15.5Lbs
 5.7KGS (+/- 10%)
MAX RIDER WEIGHT
 187Lbs
 85KGS



FIN SETUP: U.S. FINBOX + SIDE FINS (FCS B + FCS GL)
ST 9.4
LENGTH
 9'4"
 285cm
WIDTH
 22.75"
 58cm
VOLUME
 78L
WEIGHT
 16.5Lbs
 7.5KGS (+/- 10%)
MAX RIDER WEIGHT
 230Lbs
 105KGS



FIN SETUP: U.S. FINBOX + SIDE FINS (FCS B + FCS GL)
ST 9.6
LENGTH
 9'6"
 290cm
WIDTH
 28.0"
 71cm
VOLUME
 130L
WEIGHT
 21Lbs
 9.5KGS (+/- 10%)
MAX RIDER WEIGHT
 330Lbs
 150KGS

ALL NEW SERIES

DARKHORSE SERIES

SOFTBOARD / DURABLE SURF

PERFORMANCE PROFILE:

The soft board revolution is on and they are no longer simply toys. The fusion of great shapes and highly engineered construction come together in a vortex of style and performance. The all-new SIC Darkhorse is stepping up the game with its Vortex™ construction fusing the highest quality soft board technology with composite stringers and lightweight core materials to create fun and yet high-performance boards. The Darkhorse features a EPS core, the bottom and top skin are ultra-high-quality Vectra Ply reinforced polyethylene to promote speed, stiffness and durability. The rails are a high-density EVA to increase durability while being low friction, so they are comfortable on your arms when paddling. A key differentiating factor and core performance characteristic of the SIC Darkhorse is its Dullies™ (dual glassed reinforced composite rail stringers). This gives the board its unique stiffness without sacrificing its lively feel and pop! These boards are equipped with FCS Fusion compatible fin boxes and allow you to run the board as a quad or tri fin setup in the 5'8" and 6'8" lengths and a tri fin setup for the 7'4" and 8'4" lengths.

KEY FEATURES:

Vortex™ construction with Vectra Ply reinforced polyethylene skin, FCS Fusion compatible quad / tri fins, Dullies™ composite reinforced stringers, leash plug

DARKHORSE TECHNOLOGY VORTEX™ TECH

1. VORTEX™ - VECTRA PLY REINFORCED POLYETHYLENE BACKED WITH XPE FOAM TOP AND BOTTOM AND A FULL FIBERGLASS WRAP
2. DULLIES™ - DOUBLE GLASS REINFORCED STRINGERS™
3. LIGHTWEIGHT MOLDED EPS CORE
4. EVA RAIL WRAP
5. KICK TAIL PAD
6. FCS COMPATIBLE FIN BOXES
7. LEASH PLUG

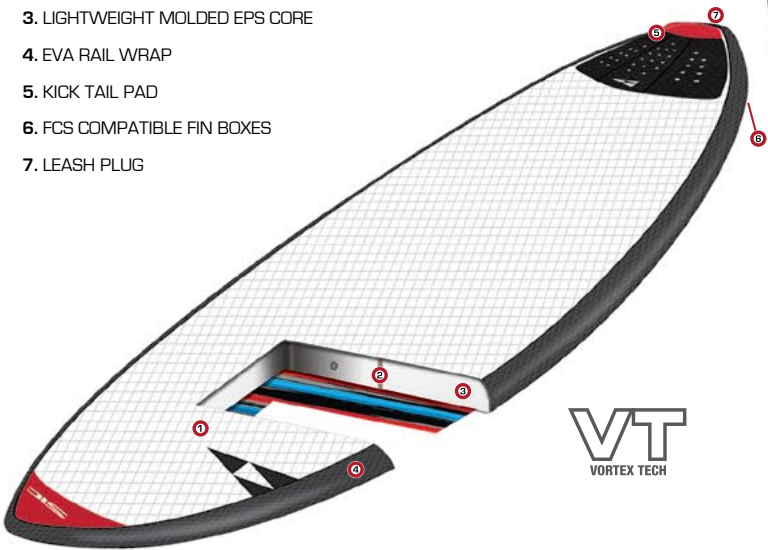

ALL NEW SERIES

DARKHORSE SURF SERIES SPECIFICATIONS

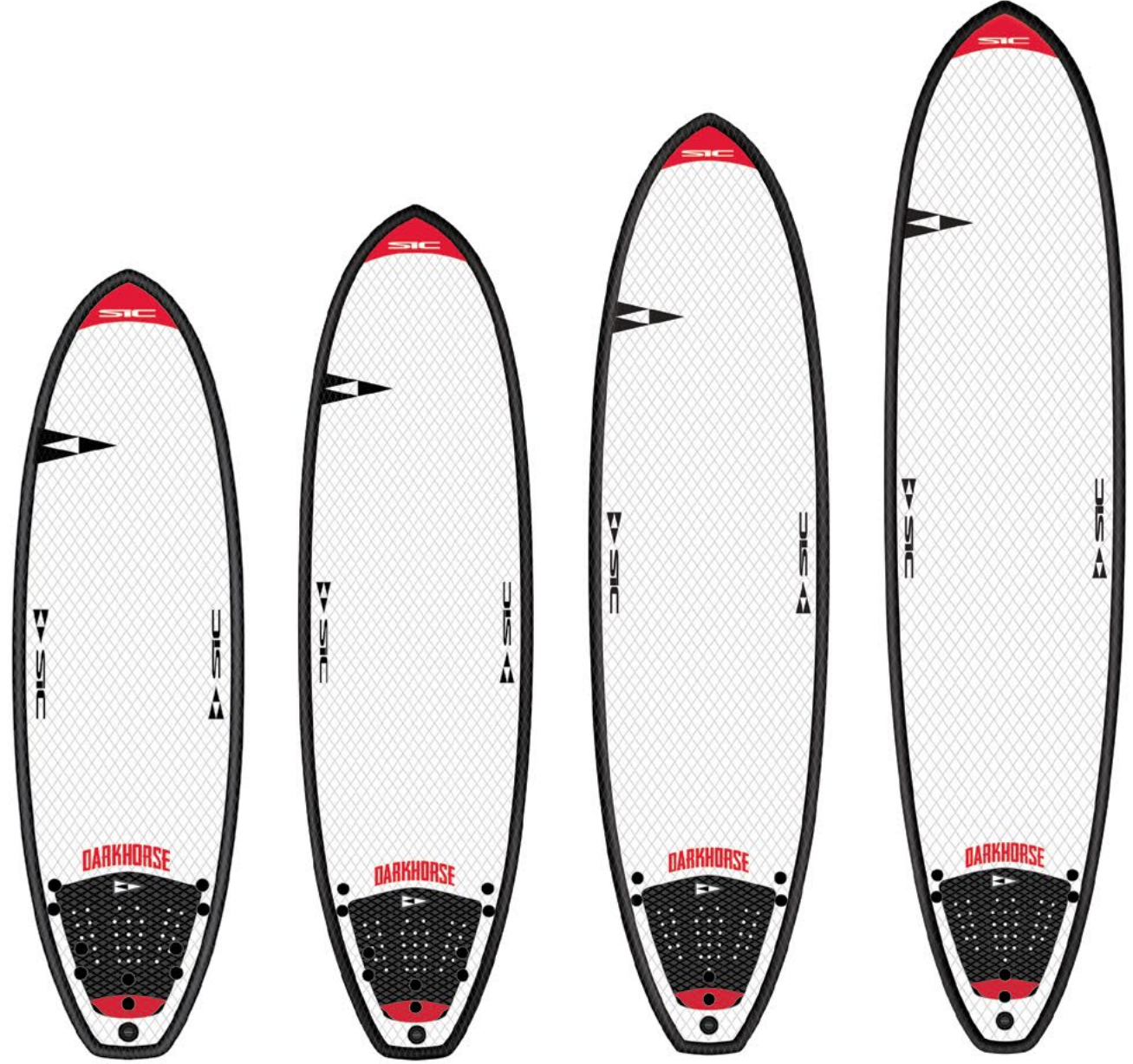

FIN SETUP: FCS FUSION COMPATIBLE QUAD / TRI FINS

VORTEX
5.8
 LENGTH
 5'8"
 167.7cm

WIDTH
 20.0"
 50.8cm

VOLUME
 35L

WEIGHT
 8.5Lbs
 4.0kgs (+/- 10%)

MAX RIDER WEIGHT
 170Lbs
 77.1kgs

FIN SETUP: FCS FUSION COMPATIBLE QUAD / TRI FINS

VORTEX
6.8
 LENGTH
 6'8"
 203.2cm

WIDTH
 22.0"
 55.9cm

VOLUME
 50L

WEIGHT
 12.3Lbs
 5.6kgs (+/- 10%)

MAX RIDER WEIGHT
 240Lbs
 108.9kgs

FIN SETUP: FCS FUSION COMPATIBLE QUAD / TRI FINS

VORTEX
7.4
 LENGTH
 7'4"
 223.5cm

WIDTH
 22.5"
 57.2cm

VOLUME
 57.6L

WEIGHT
 13.7Lbs
 6.2kgs (+/- 10%)

MAX RIDER WEIGHT
 250Lbs
 113.4kgs

FIN SETUP: FCS FUSION COMPATIBLE QUAD / TRI FINS

VORTEX
8.4
 LENGTH
 8'4"
 254cm

WIDTH
 23.0"
 58.4cm

VOLUME
 70L

WEIGHT
 14.3Lbs
 6.5kgs (+/- 10%)

MAX RIDER WEIGHT
 270Lbs
 122.5kgs

PADDLES

BATTLE 80/90 ELITE RACE

SHAFT
100% Prepreg Carbon shaft 30mm stiffness • Oval tapered • Standard 87" cut-to-length shaft • Shaft also accepts 6" Carbon T LeverLock™ handle, sold separately

GRIP
Carbon fiber Grip • Bladder molded • EVA wrapped Ergo-dynamic grip

BLADE
24K 100% Prepreg Blade (with ABS reinforced tip) • Lightweight PU core sandwich • 12 degree blade sweep for optimal power • Foiled to minimize turbulence, providing the smoothest entry/exit possible • Curved tip and concave power face for a quick catch and easy release • Blades offered in two sizes: 80,90 square inches

MALIKO 80/90 ADJ ELITE RACE MALIKO 80/90 ELITE RACE

SHAFT
100% Carbon shaft 35mm stiffness • Oval tapered • Standard 87" cut-to-length shaft • Shaft also accepts 6" Carbon T LeverLock™ handle, sold separately.

GRIP
Carbon fiber Grip • Bladder molded • EVA wrapped Ergo-dynamic grip

BLADE
12K 100% Prepreg Blade (with ABS reinforced tip) • Lightweight PU core sandwich • 12 degree blade sweep for optimal power • Foiled to minimize turbulence, providing the smoothest entry/exit possible • Curved tip and concave power face for a quick catch and easy release • Blades offered in two sizes: 80,90 square inches

BOLT 80/90 RACE | SURF | FITNESS

SHAFT
65% Carbon and 35% Glass shaft 40mm stiffness • Oval tapered • Standard 87" cut-to-length shaft • Shaft also accepts 6" Carbon T LeverLock™ handle, sold separately.

GRIP
Lightweight composite • Bladder molded • EVA wrapped Ergo-dynamic grip

BLADE
65% Prepreg Carbon and 35% Prepreg Glass Blade (with ABS reinforced tip) • 12 degree blade sweep for optimal power • Foiled to minimize turbulence, providing the smoothest entry/exit possible • Curved tip and concave power face for a quick catch and easy release • Blades offered in two sizes: 80,90 square inches

TAO 90 RECREATION | FLEET 3 PIECE 16" LEVER LOCK ADJ.

SHAFT
90% Fiberglass/ 10% Carbon shaft • 3 piece adjustable Lever Lock™ adjustability system • Fiberglass handle shaft with 16" of adjustability 70"- 86"

GRIP
ABS T Handle with Lever Lock™ clamp • Locking alignment markers

BLADE
CRFT blade for the ultimate in durability • Blade offered in one size: 90 square inches

TAO 90 RECREATION | FLEET 16" LEVER LOCK ADJ.

SHAFT
90% Fiberglass/ 10% Carbon shaft • 16" adjustable Lever Lock™ adjustability system (fits inside of SIC 3 PC paddle travel bag) • Fiberglass handle shaft with 16" of adjustability – 70"- 86"

GRIP
ABS T Handle with Lever Lock™ clamp • Locking alignment markers

BLADE
CRFT blade for the ultimate in durability • Blade offered in one size: 90 square inches

BOLT 65 2 PC YOUTH

SHAFT
100% Carbon shaft • 2 piece adjustable • 9" of adjustability 51"-60" • Round shaft • Clamp lock for adjustability

GRIP
Lightweight composite • Bladder molded • Youth specific grip

BLADE
90% Prepreg Carbon blade • Youth specific blade • 12 degree blade sweep for optimal power • Foiled to minimize turbulence, providing the smoothest entry/exit possible • Curved tip and concave power face for a quick catch and easy release • Blades offered in one size: 65 square inches

GLIDE 65 2 PC ADJ YOUTH

SHAFT
100% Glass shaft • 2 piece adjustable • 9" of adjustability 51"-60" • Round shaft • Clamp lock for adjustability

GRIP
Lightweight composite • Bladder molded • Youth specific grip

BLADE
100% prepreg glass blade • Youth specific blade • 12 degree blade sweep for optimal power • Foiled to minimize turbulence, providing the smoothest entry/exit possible • Curved tip and concave power face for a quick catch and easy release • Blades offered in one size: 65 square inches



BATTLE 80/90 CTL



MALIKO 80/90
CTL OR 6" LEVER LOCK ADJ.

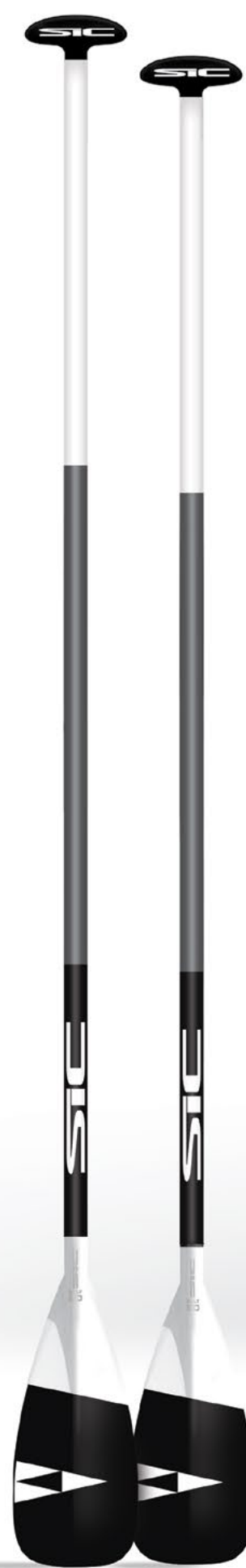

BOLT 80/90 CTL

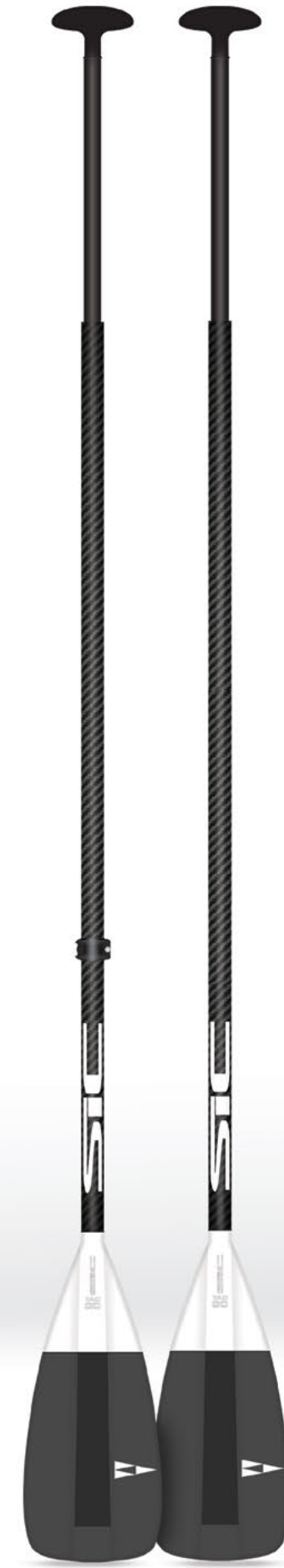

TAO 90/90
16" LEVER LOCK ADJ. OR
3 PIECE 16" LEVER LOCK ADJ.



BOLT YOUTH 65
9" CLAMP LOCK ADJ.



GLIDE YOUTH 65
9" CLAMP LOCK ADJ.

BAGS



BOARD / PADDLE FIT GUIDE:

VERTICAL SW BAG - 11.0 x 30.0

FITS:
 OKEANOS 11.0 x 28.0 (GC+)
 BULLET 11.0 x 28.25 (TWC)
 SONIC 11.0 x 29.0 (ST)

VERTICAL SW BAG - 12.6 x 24.0

FITS:
 RS 12.6 x 20.0 YOUTH (SCC+)
 RS 12.6 x 22.0 YOUTH (SCC+)
 RS 12.6 x 23.5 (SCC+)

VERTICAL SW BAG - 12.6 x 27.0

FITS:
 RS 12.6 x 25.0 (SCC+)
 BAYONET 12.6 x 26.0 (SCC+)
 RS 12.6 x 27.0 (SCC+)

VERTICAL SW BAG - 12.6 x 30.0

FITS:
 F 12.0 x 30.0 (GC)
 BULLET 12.6 x 28.25 (TWC)
 BULLET 12.6 x 28.25 (SCC+)
 X 12.6 x 29.5 (TWC)

VERTICAL SW BAG - 12.0 x 35.0

FITS:
 TAO BIG FISH 12.0 x 35.0 (ST)

VERTICAL SW BAG - 14.0 x 24.0

FITS:
 RS 14.0 x 21.5 (SCC+)
 RS 14.0 x 23.0 (SCC+)
 RS 14.0 x 24.5 (SCC+)
 BAYONET 14.0 x 24.5 (SCC+)

VERTICAL SW BAG - 14.0 x 27.0

FITS:
 BAYONET 14.0 x 26.0 (SCC+)
 RS 14.0 x 26.0 (SCC+)
 BULLET 14.0v2 x 27.25 (TWC)
 BULLET 14.0v2 x 27.25 (SCC+)

VERTICAL SW BAG - 14.0 x 30.0

FITS:
 X 14.0 x 28.5 (TWC)
 F 14.0 x 30.0 (SCC+)
 RS 14.0 x 28.0 (SCC+)

VERTICAL SW BAG - 17.4 x 28.0

FITS:
 BAYONET 17.1 x 25.0 (DCC+) w/FAST
 BULLET 17.4 x 26.6 (DCC+) w/FAST

SURF BAG - 8.8 x 29.0

FITS:
 SLICE 8.6 x 28.0 (GCC+)

SURF BAG - 9.4 x 30.0

FITS:
 SLICE 9.0 x 29.0 (GCC+)

SURF BAG - 10.0 x 34.0

FITS:
 TAO SURF 9.2 x 31.5 (ST)ART
 SLICE 9.6 x 30.0 (GCC+)
 SLICE 10.0 x 31.0 (GCC+)
 TAO FIT 10.0 x 33.0 (ST)

SURF BAG - 11.0 x 36.0

FITS:
 SABER 10.6 x 30.0 (GC+)
 TAO SURF 10.6 x 31.5 (ST)
 TAO SURF 10.6 x 31.5 (ST) ART
 SAGE 10.6 x 34.0 (GC+)
 TAO FIT 11.0 x 34.0 (ST)

SURF BAG - 11.11 x 34.0

FITS:
 SABER 11.6 x 30.0 (GC+)
 TAO SURF 11.6 x 32.5 (ST)
 TAO SURF 11.6 x 32.5 (ST) ART

TOURING BAG 12.6x30.0

FITS:
 OKEANOS 12.6 x 27.0 (GC+)
 OKEANOS 12.6 x 29.0 (GC+)
 SONIC 12.6 x 30.0 (ST)

TOURING BAG 14.0x30.0

FITS:
 OKEANOS 14.0 x 28.0 (GC+)

PRO COFFIN BAG - 12.6 x 25.0

FITS:
 RS 12.6 x 20.0 YOUTH (SCC+)
 RS 12.6 x 22.0 YOUTH (SCC+)
 RS 12.6 x 23.5 (SCC+)
 RS 12.6 x 25.0 (SCC+)

PRO COFFIN BAG - 14.0 x 25.0

FITS:
 RS 14.0 x 21.5 (SCC+)
 RS 14.0 x 23.0 (SCC+)
 RS 14.0 x 24.5 (SCC+)
 BAYONET 14.0 x 24.5 (SCC+)

BLADE SHEATH O/S

PADDLE QUIVER O/S

3-PC PADDLE BAG O/S

SOFTGOODS



LOGO T-SHIRT

100% Pre-shrunk Cotton T
SIZE: S, M, L, XL
COLORS: Black, White



SIC TRUCKER

Black hat with white SIC logo.
SIZE: One Size Fits Most
COLORS: Black



SIC PRO TRUCKER

Black hat with red stitching and white embroidered SIC logo. Hawaiian Islands embroidered side patch.
SIZE: One Size Fits Most
COLORS: Black



SIC VISOR

Black visor with white embroidered SIC logo. Hawaiian Island embroidered side patch. Quick dry material with comfort fit and inner sweat band.
SIZE: One Size Fits Most
COLORS: Black



SIC PRO HOODY

Water-resistant body, removable zip hood, thumb holes in cuffs and mp3 holder eyelet in front pocket.
10oz. 80% poly / 20% cotton
SIZE: S, M, L, XL
COLORS: Black

ACCESSORIES

WEEDLESS 7.0"

12K CARBON FIN
This fin is fast and can cut through any type of grass or kelp. Light weight with strength equals hi-performance.



WEEDLESS 8.3"

12K CARBON FIN
This fin is fast and can cut through any type of grass or kelp. Light weight with strength equals hi-performance.



DAGGER 8.0"

3K CARBON FIN
This proven winner for the F.A.S.T. equipped Bullet and Bayonet.

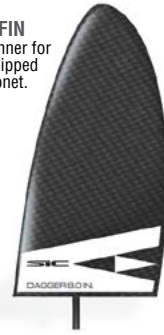

MAHI 9.0"

12K CARBON SINGLE FIN
Classic 9" Single Surf Fin. Glass / Carbon, for a standard finbox.



THREE / FOUR REG / XL

12K CARBON QUAD/TRI FIN SET
The three four is pure performance surf. This fin set can be set up as a quad or thruster and is compatible with FCS 2-Tab finboxes. Offered in standard and XL sizes.



MAHI 8.0"

NYLON SINGLE FIN
Classic 8" Single Surf Fin. For a standard finbox.



WEEDLESS 9.0"

NYLON SINGLE FIN
9" Single Touring Fin. For standard finbox.



FCS II CONNECT 9.0"

GLASS SINGLE FIN
Classic 9" Single Surf Fin. FCS II Connect.



FCS G-XQ REGULAR

GLASS / CARBON THRUSTER FIN
Thruster fin set, FCS 2-Tab



FCS HATCHET 9.0"

GLASS / CARBON SINGLE FIN
9" Single Touring Fin. Glass / Carbon, FCS II Connect.



FCS DOLPHIN FIN 10.0"

GLASS SINGLE FIN
Classic 10" Single Surf Fin. For a standard finbox.



RACK STRAPS
20' X 1"
20 FT. RACK STRAPS 2 PC SET



RACK STRAPS
13' X 1"
13 FT. RACK STRAPS 2 PC SET



RACE HANDLE
REMOVABLE
Padded removable race handle with hardware.



THULE RACK PADS
THULE COMPATIBLE / 24" LONG
Protect your boards on the roof of your vehicle with these high quality, durable rack pads from SIC. Hook-and-loop closure system makes bar installation and removal a breeze 2 high density foam pads feature durable 600D polyester fabric covers that will stand up to years of use.



RACK PADS
STANDARD ROOF RACK PADS / 24" LONG
Protect your boards on the roof of your vehicle with these high quality, durable rack pads from SIC. Fits virtually all factory racks. Premium, all-purpose rack pads for carrying SUP's, surfboards, windsurf boards and more.

STACKER PADS BOARD STACKER PADS / 22" LONG

Protect your boards with these high quality, durable stacker pads from SIC. Offers protection when stacking multiple boards on top of your vehicle. Durable 600D polyester material. No closure system.



SURF LEASH
8' X 7MM / 6' X 7MM
Molded leash, Double swivels, Triple wrap rail saver webbing, Quick release 1 1/2" calf and ankle wrap cuff, Key pocket in cuff



COIL LEASH
8' X 7MM
Molded coil leash, Double swivels, Triple wrap rail saver webbing, Quick release 1 1/2" calf and ankle wrap cuff, Key pocket in cuff



HYBRID COIL / STRAIGHT
6' X 7MM -3' + COIL
Molded coil leash, Double swivels, Triple wrap rail saver webbing, Quick release 1 1/2" calf and ankle wrap cuff, Key pocket in cuff



#BOUNDBYWATER

f facebook.com/sicmaui i instagram.com/sicmaui t @sic_maui

SIC IS DISTRIBUTED WORLD WIDE BY BIC SPORT
TO LEARN MORE OR BECOME A DEALER PLEASE CONTACT US AT:

BIC Sport

58 Rue Alain GERBAULT - Zone Industrielle du PRAT
CP 3716 - CS 23716 - 56037 VANNES Cedex - FRANCE
Tel: +33 (0)2 97 43 75 00
Fax: Tel: +33 (0)2 97 43 75 01
Email: contact-bic@bicsport.com

BIC Sport North America

2384 Cranberry Highway
West Wareham, MA 02576 - USA
Tel: (508) 291-2770
Fax: (508) 291-2772
Email: Contact-us@bicsport.com

Australia:

BIC Sport Australia Pty. Ltd.
P.O. Box 911
Manly NSW 1655
Tel. 1800 730 997
Email. info@bicsport.com.au

New Zealand:

Glide Industries (NZ) Ltd.
P.O. Box 106910
Auckland City 1143
Tel. 0800 242 776
Email. info@glideindustries.com

BIC Sport Japan

3-1-9 TSUJIDO-NISHIKAIGAN
FUJISAWA KANAGAWA
JAPAN
info@bicsportjapan.com
TEL:0466-30-1979 / FAX:0466-30-1980

